

# USB2.0 CMOS CAMERA ARTCAM-MI-WOM Series INSTRUCTION BOOKLET

0.36M pixels	ARTCAM-036MI2-WOM Series
1.3M pixels	ARTCAM-130MI-WOM Series
3.0M pixels	ARTCAM-300MI-WOM Series
5.0M pixels	ARTCAM-500MI-WOM Series
10.0M pixels	ARTCAM-1000MI-WOM Series
14.0M pixels	ARTCAM-1400MI-WOM Series

ARTRAY CO., LTD.

**ARTRAY**

# Contents

1. Attention .....	- 4 -
2. Introduction .....	- 7 -
3. Main Features.....	- 7 -
4. The Product.....	- 9 -
5. Connections.....	- 10 -
5.1. How to connect a camera .....	- 10 -
5.2. Shutter Speed.....	- 10 -
5.3. Operation clock settings .....	- 10 -
6. Specifications.....	- 11 -
6.1. Color Model.....	- 11 -
6.2. Monochrome Model.....	- 13 -
6.3. NIR Model .....	- 14 -
7. Dimensions.....	- 15 -
7.1. C-MOUNT, CASSED, USB CABLE TYPE(Small case) .....	- 15 -
7.2. C-MOUNT, CASSED, USB CABLE TYPE (Old model case).....	- 16 -
7.3. BOARD LENS, BOARD TYPE.....	- 17 -
7.4. C-MOUNT, BOARD TYPE .....	- 18 -
8. Spectral Sensitivity Characteristics .....	- 19 -
8.1. ARTCAM- 036MI2-WOM series(Color model) .....	- 19 -
8.2. ARTCAM-036MI2-BW-WOM series (Monochrome model) .....	- 19 -
8.3. ARTCAM-130MI-WOM series(Color model) .....	- 20 -
8.4. ARTCAM-130MI-BW-WOM series(Monochrome model).....	- 20 -
8.5. ARTCAM-300MI-WOM series(Color model) .....	- 21 -
8.6. ARTCAM-500MI-WOM series(Color model) .....	- 22 -
8.7. ARTCAM-500MI-BW-WOM series(Monochrome model).....	- 22 -
8.8. ARTCAM-1000MI-WOM series(Color model) .....	- 23 -
8.9. ARTCAM-1000MI-BW-WOM series(Monochrome model) .....	- 23 -
8.10. ARTCAM-1400MI-WOM series(Color model) .....	- 24 -
9. Characteristic of visible light cut filter.....	- 24 -
10. AD Conversion.....	- 25 -
10.1. ARTCAM-036MI2-WOM series / 130MI-WOM series / 300MI-WOM series / 500MI-WOM series .....	- 25 -
10.1.1. Standard functions (configurable in standard viewer/SDK) .....	- 25 -
10.1.2. Optional functions (please contact us for further details.).....	- 25 -
10.2. ARTCAM-1000MI-WOM series .....	- 26 -
10.2.1. Standard functions (configurable in standard viewer/SDK) .....	- 26 -

10.2.2.	Optional functions (please contact us for further details.).....	- 26 -
10.3.	ARTCAM-1400MI-WOM series .....	- 27 -
10.3.1.	Standard functions (configurable in standard viewer/SDK) .....	- 27 -
10.3.2.	Optional functions (please contact us for further details.).....	- 27 -
11.	Optional Functions .....	- 28 -
11.1.	Trigger Input .....	- 28 -
11.1.1.	Trigger timing chart(ARTCAM-036MI2-WOM series) .....	- 29 -
11.1.2.	Trigger timing chart(ARTCAM-130MI-WOM/300MI-WOM series).....	- 30 -
11.1.3.	Trigger timing chart(ARTCAM-500MI-WOM series) .....	- 31 -
11.2.	GPIO.....	- 32 -
12.	System Requirements .....	- 33 -
12.1.	Recommended System Requirements .....	- 33 -

# 1. Attention

## ■About this manual

1. Before using the camera, please read this manual thoroughly.
2. Please keep this manual reachable and always refer to the contents when needed.
3. Please contact us if the manual is lost or damaged. We will provide a replacement.
4. We cannot guarantee the safety of improper uses of the camera.
5. For your safety, please follow the directions of this manual.
6. All contents are subject to change.
7. Images in this manual may have been simplified to be easier comprehended.
8. Please contact us if you find any unclear points or mistakes in this manual.
9. Quoting, copying or altering some or all parts of the manual without our permission is prohibited.
10. We are not responsible for any lost or damages on your profits due to the use of our products.
11. Please understand that our oversea branches do not provide maintenance or repair services.

## ■About the Icons

To keep the safety of the user, other people and their properties, please pay attention to the following icons.



Warning

If the user fails to follow the instruction, serious injury or death may occur.



Caution

If the user fails to follow the instruction, physical injury on human or damages on hardware may occur.

#### ■ For Safe Use



## Warning

● In following circumstances, please stop using the product and turn off the power immediately to prevent the risks of fires and electric shocks. If the product is defective, please contact us for repair or exchange. For your safety, please do not disassemble, modify or repair the camera on your own.

Please stop using the product and turn off the power immediately when:

- The product becomes smoky or gets extremely hot on the surface, or makes unusual smells or sounds.
- Foreign material or water gets into the product.
- The product falls and becomes damaged.

● Do not place the product on unstable surfaces. The product may be fallen and people may get hurt.



## Caution

● Do not expose the product to steam or fumes to avoid electric shocks and fires.

● Do not leave the product in high temperature places such as inside of vehicles or under direct sunlight. High temperature may cause damages to the camera, or even cause fires.

● Do not cover the product with cloth or other materials. The product may get extremely hot and the heat may cause deformations on the parts or even cause fires.

● Please avoid dropping or shocking the product as the product may be damaged.

● Do not touch the cable with a wet hand. Such action may cause electric shocks.

● Please avoid continuously contacting the surface of the camera to your skin when the camera is being used. The surface temperature of the camera may cause burns.

#### ■ Other Notices

● Please do not use the camera under strong lights such as sun light for a long period. Also please do not expose the camera under strong lights even when the product is not being used because the sensor might be damaged.

#### ■ Maintenance

● Wipe the dirt on surface with soft cloth or tissue paper. Do not use alcohol, thinner or benzene to avoid damaging the surface paints.

■ Electro Magnetic Interference

● The camera may interfere with electronic devices such as TV and radio. Please do not place the camera next to such equipment.

■ Export Control

This product is a Catch-all Control item subject to the Foreign Exchange and Foreign Trade Act and its relevant legislations. Except for exporting to the 26 white countries designated in the Cabinet Order, export licenses are required if the products are going to be used for military use or if the end user of the product is related to all kinds of military activities. If your circumstances cause the need to apply export licenses, please notify us before you place orders. Also, please notify us in advance if the end users or purposes of use change after the purchase and thus cause the need to apply export licenses.

About the Japanese Security Export Controls, please refer to the webpage for Security Export Control Policy, the Ministry of Economy, Trade and Industry:

[www.meti.go.jp/policy/anpo/englishpage.html](http://www.meti.go.jp/policy/anpo/englishpage.html)

The above is based on the enforcement laws and regulations at the time of issuance of this document. Please be sure to check the latest laws and regulations before actually exporting this product.

■ Guarantee

To save the environment, we do not issue warranty in printed format. Instead, all records of the warranty periods, delivery dates and the customer information are well kept in our system.

For more details, please refer to the following link:

Hardware Warranty: [http://www.artray.us/download/artray\\_warranty.pdf](http://www.artray.us/download/artray_warranty.pdf)

● We do not guarantee the functions of this product or the descriptions on this manual to be completely adapted to the users' end applications or marketing purposes. We are also not held responsible for any direct or indirect damages caused by our products under any circumstances.

● Please do not use this product for a task that requires high reliability. This product is not manufactured to be used as medical, nuclear, aerospace, transportation equipment or equipment or that is highly related to human safety. We are not held responsible for any damages on the users' property, equipment or personal safety caused by this product.

■ Disposal

● To dispose this product, please return the camera to us. If you decide to dispose the camera without returning it to us, please follow related regulations and have the camera disposed as an industrial waste. Please always keep track of the disposal, and make sure the disposed camera cannot be accessed or used by any third party.

## 2. Introduction

ARTCAM-MI-WOM Series is CMOS cameras for industrial use.

This series adopt USB2.0 interface, so the data can be delivered to PC directly without a capture board.

Cameras are equipped with on board memory which avoid data missing during transfer.

We provide a variety including cased cameras, board cameras which can be easily incorporated to other equipment, and so on.

## 3. Main Features

- High Resolution, High Frame Rate

We provide high speed CMOS cameras of a wide range of resolutions from 0.36 mega pixels to 14 mega pixels.

- USB2.0 Interface

Our cameras adopt USB2.0 interface, so the data can be delivered to PC directly and no capture board is needed.

- Small and Light

Our cameras are small and light, thus can be easily installed according to your desires.

Also, the board type camera with small type board lens is easy to be incorporated with other machines.

- Varieties to Your Needs

We provide a variety including cased cameras, board type cameras, C-Mount board type cameras.

Also, we provide color and monochrome models to meet customers' needs.

For ARTCAM-036MI2-WOM / 130MI-WOM / 500MI-WOM series, monochrome and near infrared types are also available upon your choice.

- ROI (Region Of Interest)

One major benefit of CMOS sensor is the ROI function which enables readout of designated partial images with a faster transmission speed.

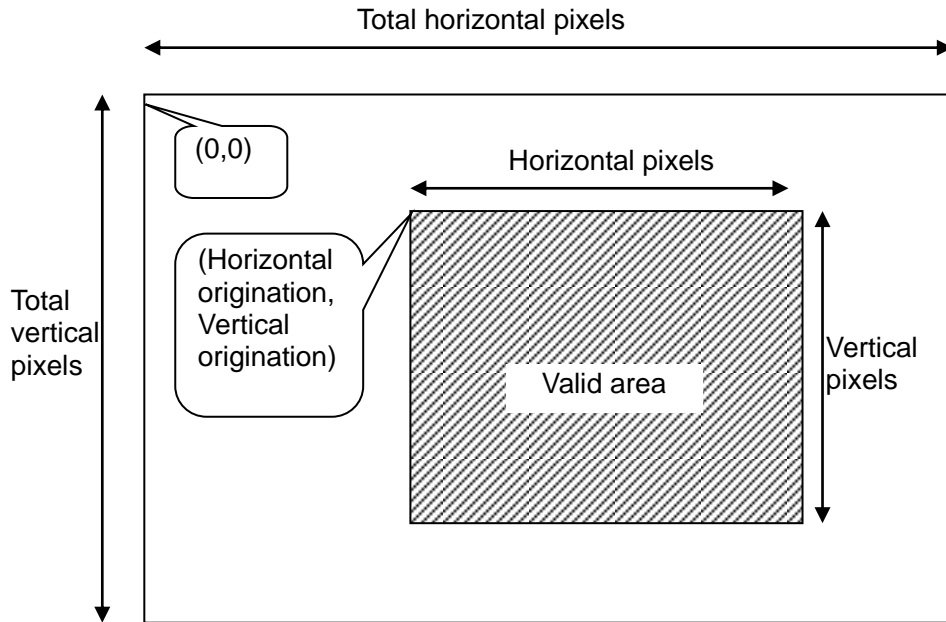

- Sub-sampling function (not available on ARTCAM-036MI2-WOM)

This function results in a more pleasing output image with reduced subsampling artifacts and improves the frame rate.

R	G	R	G	R	G	R	G	R	G
G	B	G	B	G	B	G	B	G	B
R	G	R	G	R	G	R	G	R	G
G	B	G	B	G	B	G	B	G	B
R	G	R	G	R	G	R	G	R	G
G	B	G	B	G	B	G	B	G	B
R	G	R	G	R	G	R	G	R	G
G	B	G	B	G	B	G	B	G	B
R	G	R	G	R	G	R	G	R	G
G	B	G	B	G	B	G	B	G	B

1/2 Sub-sampling mode

R	G	R	G	R	G	R	G	R	G	R	G	R	G	R	G
G	B	G	B	G	B	G	B	G	B	G	B	G	B	G	B
R	G	R	G	R	G	R	G	R	G	R	G	R	G	R	G
G	B	G	B	G	B	G	B	G	B	G	B	G	B	G	B
R	G	R	G	R	G	R	G	R	G	R	G	R	G	R	G
G	B	G	B	G	B	G	B	G	B	G	B	G	B	G	B
R	G	R	G	R	G	R	G	R	G	R	G	R	G	R	G
G	B	G	B	G	B	G	B	G	B	G	B	G	B	G	B
R	G	R	G	R	G	R	G	R	G	R	G	R	G	R	G
G	B	G	B	G	B	G	B	G	B	G	B	G	B	G	B
R	G	R	G	R	G	R	G	R	G	R	G	R	G	R	G
G	B	G	B	G	B	G	B	G	B	G	B	G	B	G	B

1/4 Sub-sampling mode

- Global Shutter(ARTCAM-036MI2-WOM series)

ARTCAM-036MI2-WOM series adopts global shutter which is very suitable for machine vision.

- Mirror function

Mirror could be processed either on the sensors or on the viewer software (ART-Viewer).

	036MI2-WOM	130MI-WOM	300MI-WOM	500MI-WOM	1000MI-WOM	1400MI-WOM
Horizontal direction	Sensor	Software	Software	Sensor	Sensor	Software
Vertical direction	Sensor	Software	Sensor	Sensor	Sensor	Sensor

\*If mirror function is processed on software, the CPU load may become high and may cause image transfer error.



- Bounded Viewer Software

We provide the Viewer Software - ART-Viewer (Windows 7/8/8.1/10).

With this software, users can easily preview, save images and change camera settings.

- 2D Measurement & Filing Software(Optional)

Useful 2D measuring functions are available with the optional 2D Measuring & Filing Software - ART-MEASURE.

- Included Software Development Kit

When developing image processing software, a software development kit that enables you to acquire Camera image acquisition and camera control are possible with other applications is included as standard.

You can also download it from the website below.

[http://www.artray.us/download\\_sdk.html](http://www.artray.us/download_sdk.html)

## 4. The Product

- 1) Camera
- 2) USB2.0 cable (Type A-B connector cable, 3m approx.)
- 3) Introduction Booklet
- 4) Viewer software and Device driver CD
- 5) Software Development Kit [ARTCCM-SDK]

<Options>

- 1) C Mount Lens
- 2) 2D Measurement & Filing Software [ART-MEASURE]
- 3) LabView DLL
- 4) 5m extension cable with USB2.0 repeater

## 5. Connections

### 5.1. How to connect a camera

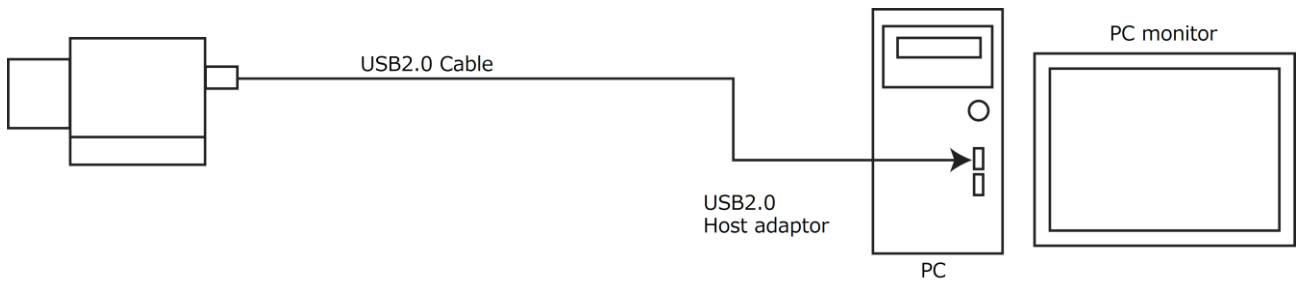

### 5.2. Shutter Speed

Shutter speed can be changed on the standard viewer software ART-Viewer.

The shutter speed is set directly on the sensor register, so please refer to the following formulas for the real exposure time.

Model	Method
036MI2-WOM Series	Range : 1~32767(Exposure Time : 1/33149~0.988 sec) *1 External trigger value : 2~32767 $\text{Exposure Time} = (\text{Shutter Value} \times (640+64)) \times 0.0417 \quad [\mu \text{sec}]$ at 24MHz
130MI-WOM Series	Range : 1~16383(Exposure Time : 1/35928~0.52 sec) $\text{Exposure Time} = (\text{Shutter Value} \times (1280+244) - 180) \times 0.020833 \quad [\mu \text{sec}]$ at 48MHz
300MI-WOM Series	Range : 1~16383(Exposure Time : 1/19688~0.832 sec) $\text{Exposure Time} = (\text{Shutter Value} \times (2048+390)) \times 0.020833 \quad [\mu \text{sec}]$ at 48MHz
500MI-WOM Series	Range : 1~16383(Exposure Time : 1/53452~1.196 sec) $\text{Exposure Time} = ((\text{Shutter Value} \times (2592+912)) - 2606) \times 0.020833 \quad [\mu \text{sec}]$ at 48MHz
1000MI-WOM Series	Range : 1~16383(Exposure Time : 1/11678~1.4 sec) $\text{Exposure Time} = (\text{Shutter Value} \times (3856+254)) \times 0.020833 \quad [\mu \text{sec}]$ at 48MHz
1400MI-WOM Series	Range : 1~16383(Exposure Time : 1/9756~1.68 sec) $\text{Exposure Time} = (\text{Shutter Value} \times (4608+312)) \times 0.020833 \quad [\mu \text{sec}]$ at 48MHz

### 5.3. Operation clock settings

Users can switch the operation clock between 48MHz / 24MHz / 12MHz with the standard viewer software or SDK.

\*1 48MHz is not available on ARTCAM-036MI2-WOM series.

## 6. Specifications

### 6.1. Color Model

	ARTCAM- 036MI2-WOM 036MI2-WOM-OP 036MI2-WOM-OP-CM	ARTCAM- 130MI-WOM 130MI-WOM-OP 130MI-WOM-OP-CM	ARTCAM- 300MI-WOM 300MI-WOM-OP 300MI-WOM-OP-CM
Sensor Type	CMOS Color Image Sensor		
Active Pixels	752(H) × 480(V)	1280(H) × 1024(V)	2048(H) × 1536(V)
Active Imager Size	4.51(H) × 2.88(V)mm 1/3"	6.66(H) × 5.32(V)mm 1/2"	6.55(H) × 4.92(V)mm 1/2"
Scan Mode	Progressive Scan		
Pixel Size	6.0(H) × 6.0(V) μm	5.2(H) × 5.2(V) μm	3.2(H) × 3.2(V) μm
Shutter Type	Global Shutter	Rolling Shutter	
Color Filter Array	RGB Bayer Pattern		
Frame Rate	60fps	30fps	12fps
Shutter Speed	1/33149~0.988s at 24MHz	1/35928~0.52s at 48MHz	1/19688~0.832s at 48MHz
Interface	USB2.0 Bulk Transfer		
Synchronization System	Internal Synchronization		
Lens Mount	C Mount (036MI2-WOM, 036MI2-WOM-OP-CM) Board lens Mount M12 P0.5 (036MI2-WOM-OP)	C Mount (130MI-WOM, 130MI-WOM-OP-CM) Board lens Mount M12 P0.5 (130MI-WOM-OP)	C Mount (300MI-WOM, 300MI-WOM-OP-CM) Board lens Mount M12 P0.5 (300MI-WOM-OP)
Power	DC5V(Supplied by USB port)		
Power Consumption	Under Approx.2W		
Ambient Conditions	Operating Temperature/Humidity : 0~35° C/10~80%(Non condensing) Storage Temperature/Humidity : 0~60° C /10~95%(Non condensing)		
External Dimensions	50(W) × 47(H) × 41.7(D)mm (036MI2-WOM) 43.5(W) × 43.5(H) × 26.2(D)mm (036MI2-WOM-OP) 50(W) × 47(H) × 28.6(D)mm (036MI2-WOM-OP-CM) *Lens, tripod mount not included	50(W) × 47(H) × 41.7(D)mm (130MI-WOM) 43.5(W) × 43.5(H) × 26.2(D)mm (130MI-WOM-OP) 50(W) × 47(H) × 28.6(D)mm (130MI-WOM-OP-CM) *Lens, tripod mount not included	50(W) × 47(H) × 41.7(D)mm (300MI-WOM) 43.5(W) × 43.5(H) × 26.2(D)mm (300MI-WOM-OP) 50(W) × 47(H) × 28.6(D)mm (300MI-WOM-OP-CM) *Lens, tripod mount not included
Weight	Approx.110g(036MI2-WOM) Approx.30g(036MI2-WOM-OP) Approx.70g(036MI2-WOM-OP-CM) *Lens,tripod mount and cable not included	Approx.110g(130MI-WOM) Approx.30g(130MI-WOM-OP) Approx.70g(130MI-WOM-OP-CM) *Lens,tripod mount and cable not included	Approx.110g(300MI-WOM) Approx.30g(300MI-WOM-OP) Approx.70g(300MI-WOM-OP-CM) *Lens,tripod mount and cable not included

	ARTCAM- 500MI-WOM 500MI-WOM-OP 500MI-WOM-OP-CM	ARTCAM- 1000MI-WOM 1000MI-WOM-OP 1000MI-WOM-OP-CM	ARTCAM- 1400MI-WOM 1400MI-WOM-OP 1400MI-WOM-OP-CM
Sensor Type	CMOS Color Image Sensor		
Active Pixels	2592(H) × 1944(V)	3856(H) × 2764(V)	4608(H) × 3288(V)
Active Imager Size	5.70(H) × 4.28(V)mm 1/2.5"	6.41(H) × 4.59(V)mm 1/2.3"	6.45(H) × 4.60(V)mm 1/2.3"
Scan Mode	Progressive Scan		
Pixel Size	2.2(H) × 2.2(V) μm	1.67(H) × 1.67(V) μm	1.4(H) × 1.4(V) μm
Shutter Type	Rolling Shutter		
Color Filter Array	RGB Bayer Pattern		
Frame Rate	7.5fps	4.4fps	3.0fps
Shutter Speed	1/53452~1.196s at 48MHz	1/11678~1.4s at 48MHz	1/9756~1.68s at 48MHz
Interface	USB2.0 Bulk Transfer		
Synchronization System	Internal Synchronization		
Lens Mount	C Mount (500MI-WOM, 500MI-WOM-OP-CM) Board lens Mount M12 P0.5 (500MI-WOM-OP)	C Mount (1000MI-WOM, 1000MI-WOM-OP-CM) Board lens Mount M12 P0.5 (1000MI-WOM-OP)	C Mount (1400MI-WOM, 1400MI-WOM-OP-CM) Board lens Mount M12 P0.5 (1400MI-WOM)
Power	DC5V(Supplied by USB port)		
Power Consumption	Under Approx.2W		
Ambient Conditions	Operating Temperature/Humidity : 0~35° C/10~80%(Non condensing) Storage Temperature/Humidity : 0~60° C /10~95%(Non condensing)		
External Dimensions	50(W) × 47(H) × 41.7(D)mm (500MI-WOM) 43.5(W) × 43.5(H) × 26.2(D)mm (500MI-WOM-OP) 50(W) × 47(H) × 28.6(D)mm (500MI-WOM-OP-CM) *Lens, tripod mount not included	50(W) × 47(H) × 49.7(D)mm (1000MI-WOM) 43.5(W) × 43.5(H) × 26.2(D)mm (1000MI-WOM-OP) 50(W) × 47(H) × 28.6(D)mm (1000MI-WOM-OP-CM) *Lens, tripod mount not included	50(W) × 47(H) × 49.7(D)mm (1400MI-WOM) 43.5(W) × 43.5(H) × 26.2(D)mm (1400MI-WOM-OP) 50(W) × 47(H) × 28.6(D)mm (1400MI-WOM-OP-CM) *Lens, tripod mount not included
Weight	Approx.110g(500MI-WOM) Approx.30g(500MI-WOM-OP) Approx.70g(500MI-WOM-OP-CM) *Lens,tripod mount and cable not included	Approx.110g(1000MI-WOM) Approx.30g(1000MI-WOM-OP) Approx.70g(1000MI-WOM-OP-CM) *Lens,tripod mount and cable not included	Approx.110g(1400MI-WOM) Approx.30g(1400MI-WOM-OP) Approx.70g(1400MI-WOM-OP-CM) *Lens,tripod mount and cable not included

## 6.2. Monochrome Model

	ARTCAM- 036MI2-BW-WOM 036MI2-BW-WOM-OP 036MI2-BW-WOM-OP-CM	ARTCAM- 130MI-BW-WOM 130MI-BW-WOM-OP 130MI-BW-WOM-OP-CM	ARTCAM- 500MI-BW-WOM 500MI-BW-WOM-OP 500MI-BW-WOM-OP-CM	ARTCAM- 1000MI-BW-WOM 1000MI-BW-WOM-OP 1000MI-BW-WOM-OP-CM
Sensor Type	CMOS Monochrome Image Sensor			
Active Pixels	752(H) × 480(V)	1280 (H) × 1024(V)	2592(H) × 1944(V)	3856(H) × 2764(V)
Active Imager Size	4.51(H) × 2.88(V)mm 1/3"	6.66(H) × 5.32(V)mm 1/2"	5.70(H) × 4.28(V)mm 1/2.5"	6.41(H) × 4.59(V)mm 1/2.3"
Scan Mode	Progressive Scan			
Pixel Size	6.0(H) × 6.0(V) μm	5.2 (H) × 5.2(V) μm	2.2(H) × 2.2(V) μm	1.67(H) × 1.67(V) μm
Shutter Type	Global Shutter	Rolling Shutter		
Frame Rate	60fps	30fps	7.5fps	4.4fps
Shutter Speed	1/33149~0.988s at 24MHz	1/35928~0.52s at 48MHz	1/53452~1.196s at 48MHz	1/11678~1.4s at 48MHz
Interface	USB2.0 Bulk Transfer			
Synchronization System	Internal Synchronization			
Lens Mount	C Mount (036MI2-BW-WOM, 036MI2-BW-WOM-OP-CM) Board lens Mount M12 P0.5 (036MI2-BW-WOM-OP)	C Mount (130MI-BW-WOM, 130MI-BW-WOM-OP-CM) Board lens Mount M12 P0.5 (130MI-BW-WOM-OP)	C Mount (500MI-BW-WOM, 500MI-BW-WOM-OP-CM) Board lens Mount M12 P0.5 (500MI-BW-WOM-OP)	C Mount (1000MI-BW-WOM, 1000MI-BW-WOM-OP-CM) Board lens Mount M12 P0.5 (1000MI-BW-WOM-OP)
Power	DC5V(Supplied by USB port)			
Power Consumption	Under Approx.2W			
Ambient Conditions	Operating Temperature/Humidity : 0~35° C /10~80%(Non condensing) Storage Temperature/Humidity : 0~60° C /10~95%(Non condensing)			
External Dimensions	50(W) × 47(H) × 41.7(D)mm (036MI2-BW-WOM) 43.5(W) × 43.5(H) × 26.2(D)mm (036MI2-BW-WOM-OP) 50(W) × 47(H) × 28.6(D)mm (036MI2-BW-WOM-OP-CM) *Lens, tripod mount not included	50(W) × 47(H) × 41.7(D)mm (130MI-BW-WOM) 43.5(W) × 43.5(H) × 26.2(D)mm (130MI-BW-WOM-OP) 50(W) × 47(H) × 28.6(D)mm (130MI-BW-WOM-OP-CM) *Lens, tripod mount not included	50(W) × 47(H) × 41.7(D)mm (500MI-BW-WOM) 43.5(W) × 43.5(H) × 26.2(D)mm (500MI-BW-WOM-OP) 50(W) × 47(H) × 28.6(D)mm (500MI-BW-WOM-OP-CM) *Lens, tripod mount not included	50(W) × 47(H) × 49.7(D)mm (1000MI-BW-WOM) 43.5(W) × 43.5(H) × 26.2(D)mm (1000MI-BW-WOM-OP) 50(W) × 47(H) × 28.6(D)mm (1000MI-BW-WOM-OP-CM) *Lens, tripod mount not included
Weight	Approx.110g (036MI2-BW-WOM) Approx.30g (036MI2-BW-WOM-OP) Approx.70g (036MI2-BW-WOM-OP-CM) *Lens, tripod mount and cable not included	Approx.110g (130MI-BW-WOM) Approx.30g (130MI-BW-WOM-OP) Approx.70g (130MI-BW-WOM-OP-CM) *Lens, tripod mount and cable not included	Approx.110g (500MI-BW-WOM) Approx.30g (500MI-BW-WOM-OP) Approx.70g (500MI-BW-WOM-OP-CM) *Lens, tripod mount and cable not included	Approx.110g (1000MI-BW-WOM) Approx.30g (1000MI-BW-WOM-OP) Approx.70g (1000MI-BW-WOM-OP-CM) *Lens, tripod mount and cable not included

### 6.3. NIR Model

	ARTCAM- 036MI2-NIR-WOM 036MI2-NIR-WOM-OP 036MI2-NIR-WOM-OP-CM	ARTCAM- 130MI-NIR-WOM 130MI-NIR-WOM-OP 130MI-NIR-WOM-OP-CM	ARTCAM- 500MI-NIR-WOM 500MI-NIR-WOM-OP 500MI-NIR-WOM-OP-CM
Sensor Type	CMOS Monochrome Image Sensor		
Active Pixels	752(H) × 480(V)	1280 (H) × 1024(V)	2592(H) × 1944(V)
Active Imager Size	4.51(H) × 2.88(V)mm 1/3"	6.66(H) × 5.32(V)mm 1/2"	5.70(H) × 4.28(V)mm 1/2.5"
Scan Mode	Progressive Scan		
Pixel Size	6.0(H) × 6.0(V) μm	5.2 (H) × 5.2(V) μm	2.2(H) × 2.2(V) μm
Shutter Type	Global Shutter	Rolling Shutter	
Frame Rate	60fps	30fps	7.5fps
Shutter Speed	1/33149~0.988s at 24MHz	1/35928~0.52s at 48MHz	1/53452~1.196s at 48MHz
Interface	USB2.0 Bulk Transfer		
Synchronization System	Internal Synchronization		
Lens Mount	C MOUNT (036MI2-NIR-WOM, 036MI2-NIR-WOM -OP-CM) Board lens Mount M12 P0.5 (036MI2-NIR-WOM-OP)	C MOUNT (130MI-NIR-WOM, 130MI-NIR -WOM-OP-CM) Board lens Mount M12 P0.5 (130MI-NIR-WOM-OP)	C MOUNT (500MI-NIR-WOM, 500MI-NIR -WOM-OP-CM) Board lens Mount M12 P0.5 (500MI-NIR-WOM-OP)
Power	DC5V(Supplied by USB port)		
Power Consumption	Under Approx.2W		
Ambient Conditions	Operating Temperature/Humidity : 0~35° C /10~80%(Non condensing) Storage Temperature/Humidity : 0~60° C /10~95%(Non condensing)		
External Dimensions	50(W) × 47(H) × 41.7(D)mm (036MI2-NIR-WOM) 43.5(W) × 43.5(H) × 26.2(D)mm (036MI2-NIR-WOM-OP) 50(W) × 47(H) × 28.6(D)mm (036MI2-NIR -WOM-OP-CM) *Lens and cable not included	50(W) × 47(H) × 41.7(D)mm (130MI-NIR-WOM) 43.5(W) × 43.5(H) × 26.2(D)mm (130MI-NIR-WOM-OP) 50(W) × 47(H) × 28.6(D)mm (130MI-NIR-WOM-OP-CM) *Lens and cable not included	50(W) × 47(H) × 41.7(D)mm (500MI-NIR-WOM) 43.5(W) × 43.5(H) × 26.2(D)mm (500MI-NIR-WOM-OP) 50(W) × 47(H) × 28.6(D)mm (500MI-NIR-WOM-OP-CM) *Lens and cable not included
Weight	Approx.110g (036MI2-NIR-WOM) Approx.30g (036MI2-NIR-WOM-OP) Approx.70g (036MI2-NIR-WOM-OP-CM) *Lens, tripod mount and cable not included	Approx.110g (130MI-NIR-WOM) Approx.30g (130MI-NIR-WOM-OP) Approx.70g (130MI-NIR-WOM-OP-CM) *Lens, tripod mount and cable not included	Approx.110g (500MI-NIR-WOM) Approx.30g (500MI-NIR-WOM-OP) Approx.70g (500MI-NIR-WOM-OP-CM) *Lens, tripod mount and cable not included

# 7. Dimensions

## 7.1. C-MOUNT, CASED, USB CABLE TYPE(Small case)

ARTCAM-036MI2-WOM / 036MI2-BW-WOM / 036MI2-NIR-WOM

ARTCAM-130MI-WOM / 130MI-BW-WOM / 130MI-NIR-WOM

ARTCAM-300MI-WOM

ARTCAM-500MI-WOM / 500MI-BW-WOM / 500MI-NIR-WOM

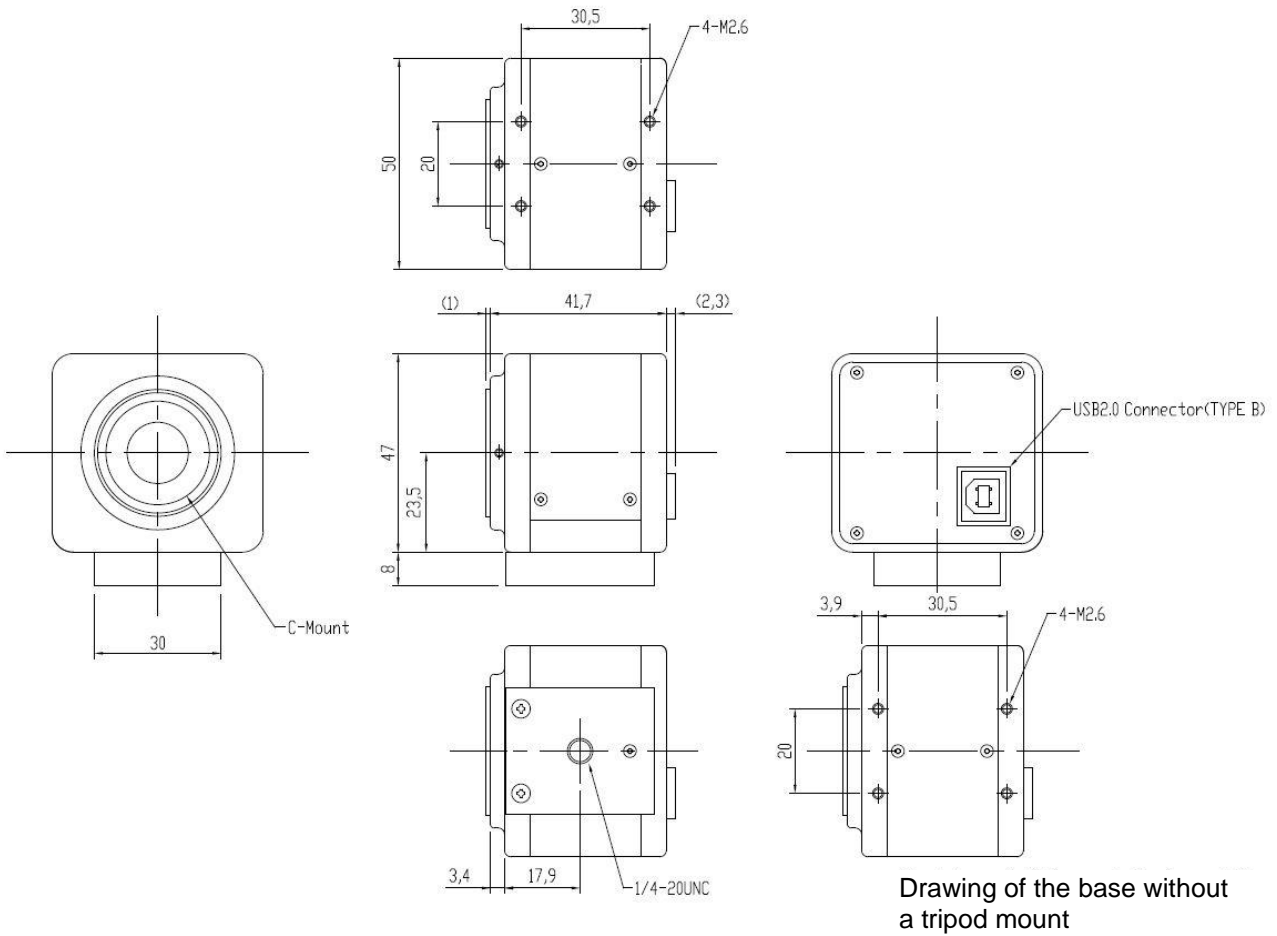

\*The design has changed into the small case model of this outline drawing for orders after Aug, 2012.

## 7.2. C-MOUNT, CASED, USB CABLE TYPE (Old model case)

ARTCAM-036MI2-WOM / 036MI2-BW-WOM / 036MI2-NIR-WOM

ARTCAM-130MI-WOM / 130MI-BW-WOM / 130MI-NIR-WOM

ARTCAM-300MI-WOM

ARTCAM-500MI-WOM / 500MI-BW-WOM / 500MI-NIR-WOM

ARTCAM-1000MI-WOM / 1000MI-BW-WOM

ARTCAM-1400MI-WOM

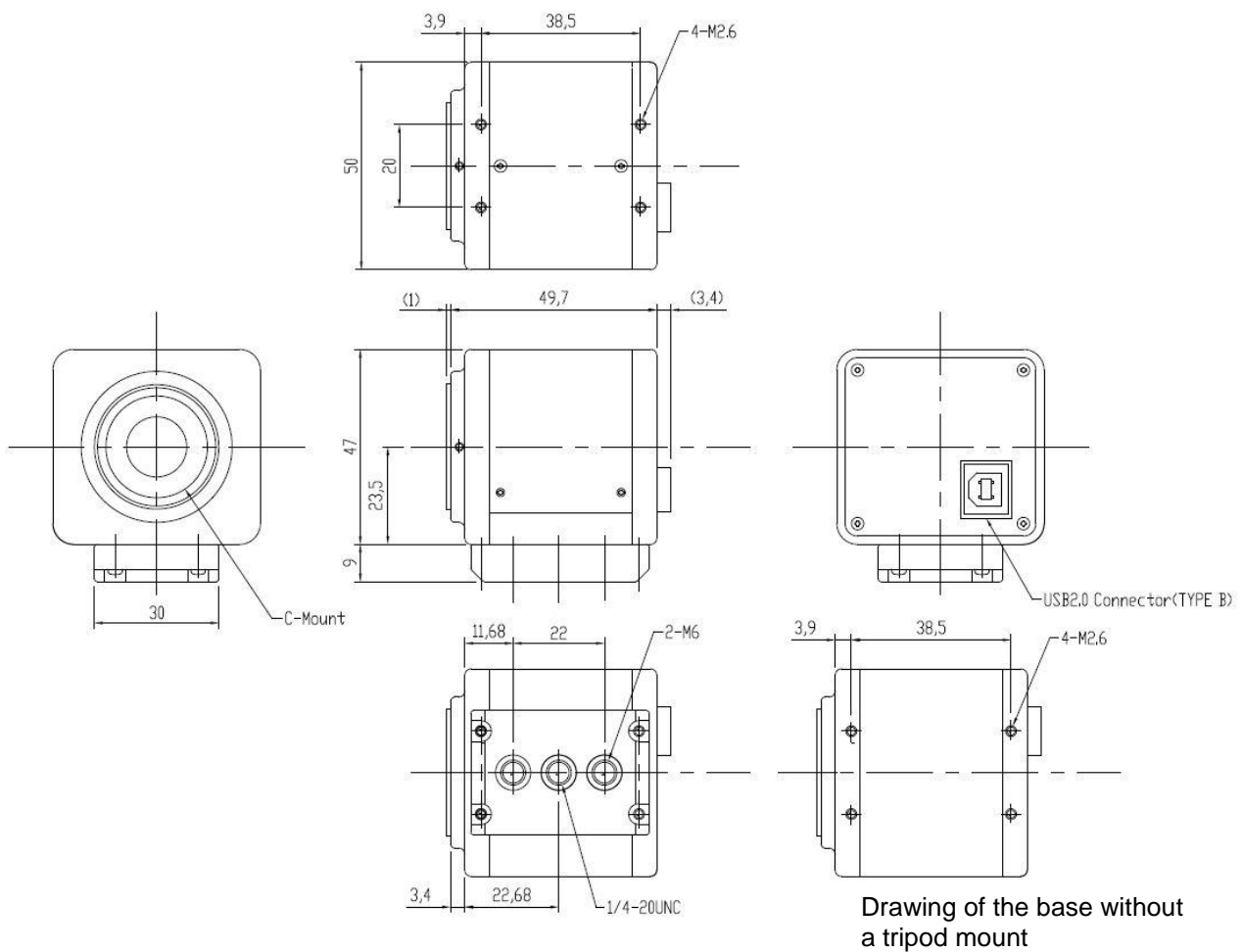

\*It is an outline drawing of previous case.  
It is also possible to use the same case.



### 7.3. BOARD LENS, BOARD TYPE

ARTCAM-036MI2-WOM-OP / 036MI2—BW-WOM-OP / 036MI2-NIR-WOM-OP

ARTCAM-130MI-WOM-OP / 130MI-BW-WOM-OP / 130MI-NIR-WOM-OP

ARTCAM-300MI-WOM-OP

ARTCAM-500MI-WOM-OP / 500MI-BW-WOM-OP / 500MI-NIR-WOM-OP

ARTCAM-1000MI-WOM-OP / 1000MI-BW-WOM-OP

ARTCAM-1400MI-WOM-OP

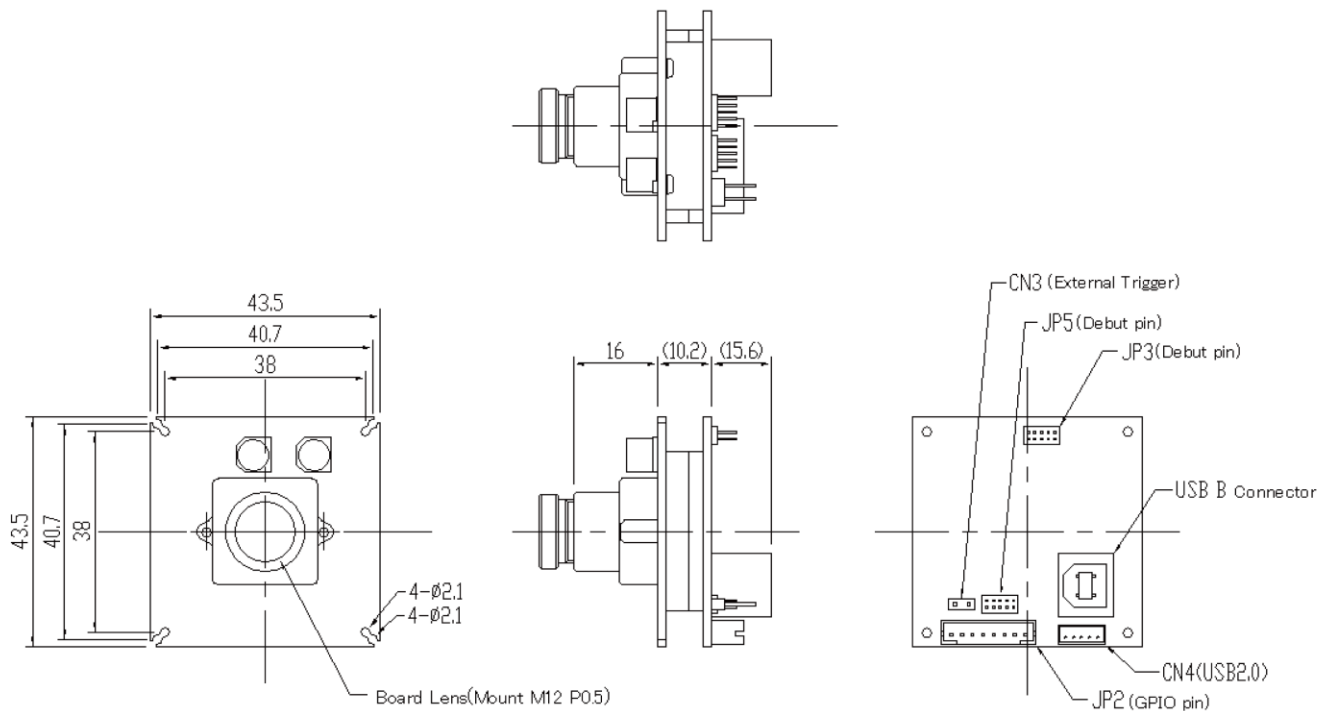

\*Depending on different models, size and position of components in front of sensor board (condenser...) might vary.

## 7.4. C-MOUNT, BOARD TYPE

ARTCAM-036MI2-WOM-OP-CM / 036MI2-BW-WOM-OP-CM / 036MI2-NIR-WOM-OP-CM

ARTCAM-130MI-WOM-OP-CM / 130MI-BW-WOM-OP-CM / 130MI-NIR-WOM-OP-CM

ARTCAM-300MI-WOM-OP-CM

ARTCAM-500MI-WOM-OP-CM / 500MI-BW-WOM-OP-CM / 500MI-NIR-WOM-OP-CM

ARTCAM-1000MI-WOM-OP / 1000MI-BW-WOM-OP-CM

ARTCAM-1400MI-WOM-OP

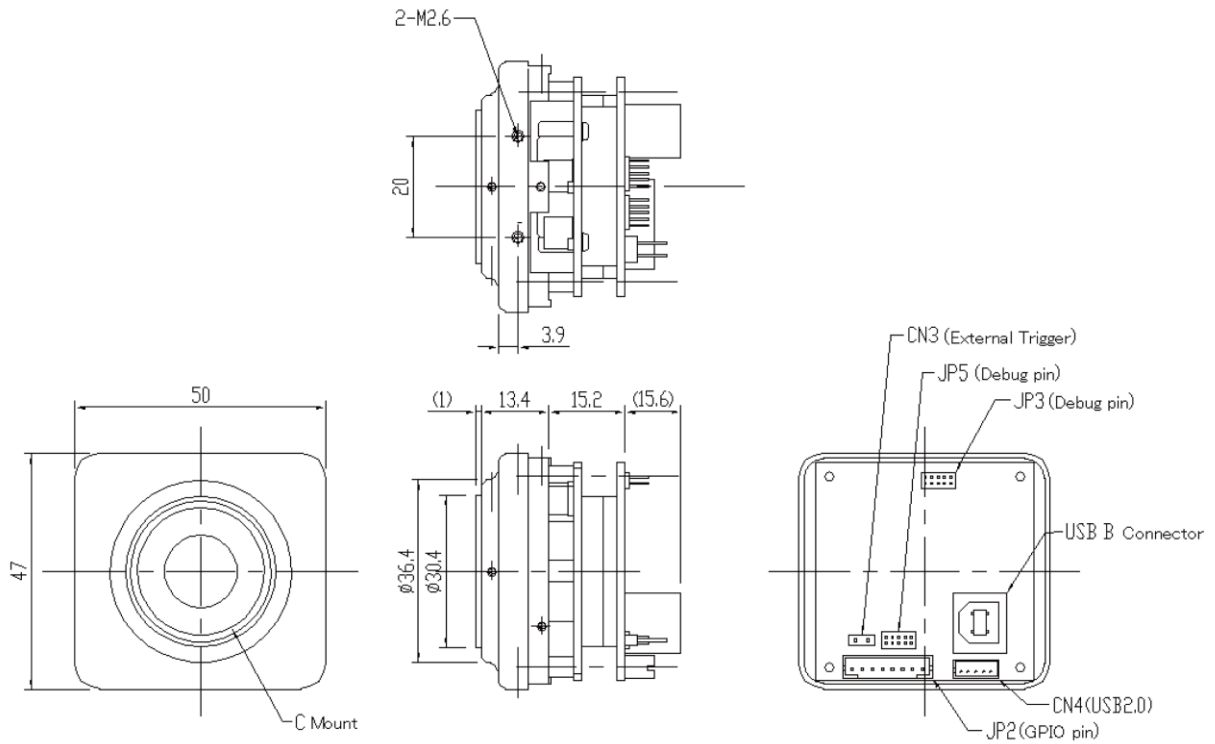

## 8. Spectral Sensitivity Characteristics

### 8.1. ARTCAM- 036MI2-WOM series(Color model)

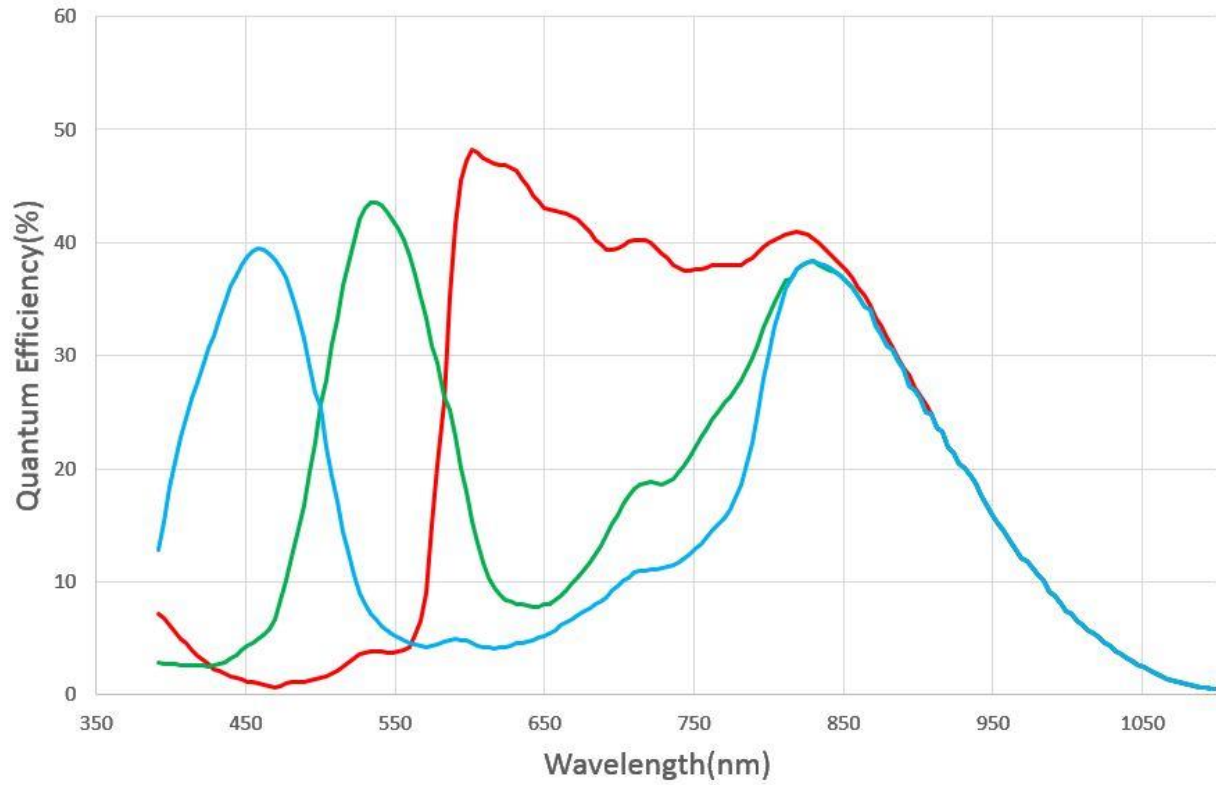

### 8.2. ARTCAM-036MI2-BW-WOM series (Monochrome model)

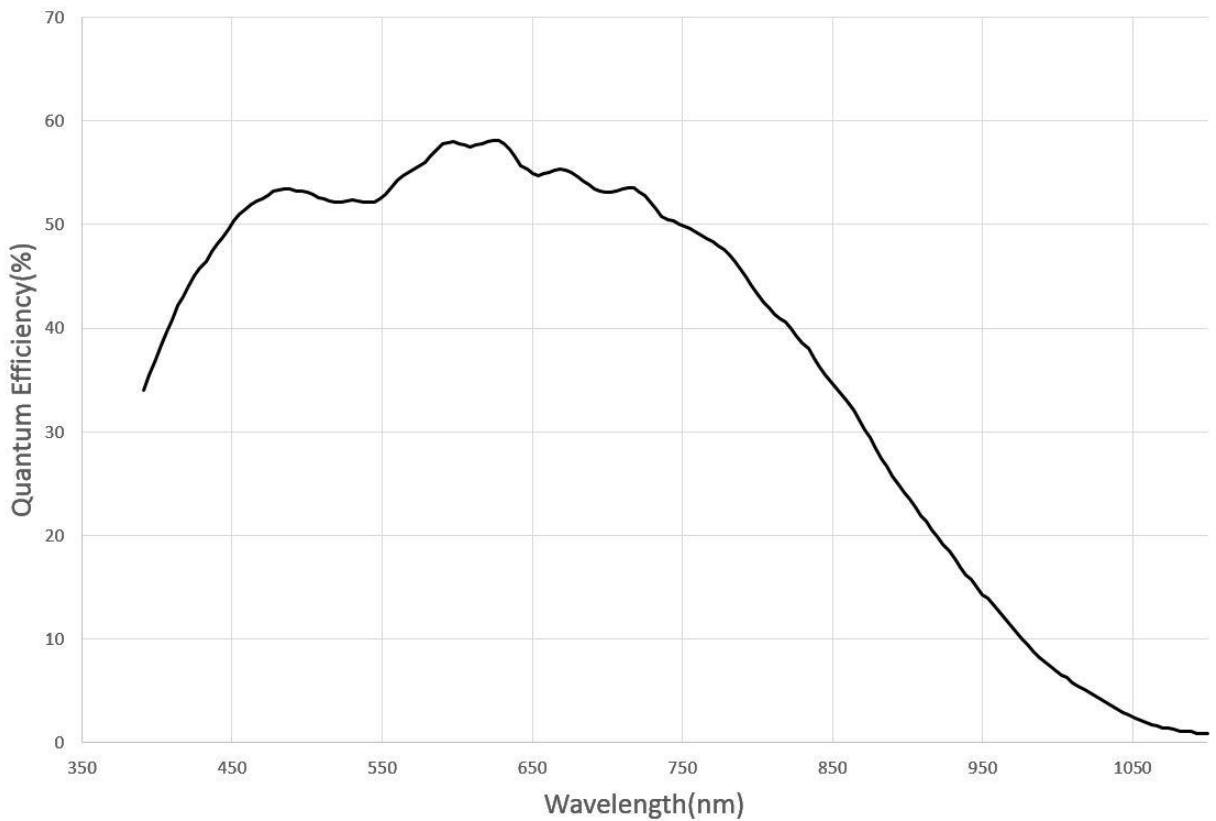

### 8.3. ARTCAM-130MI-WOM series(Color model)

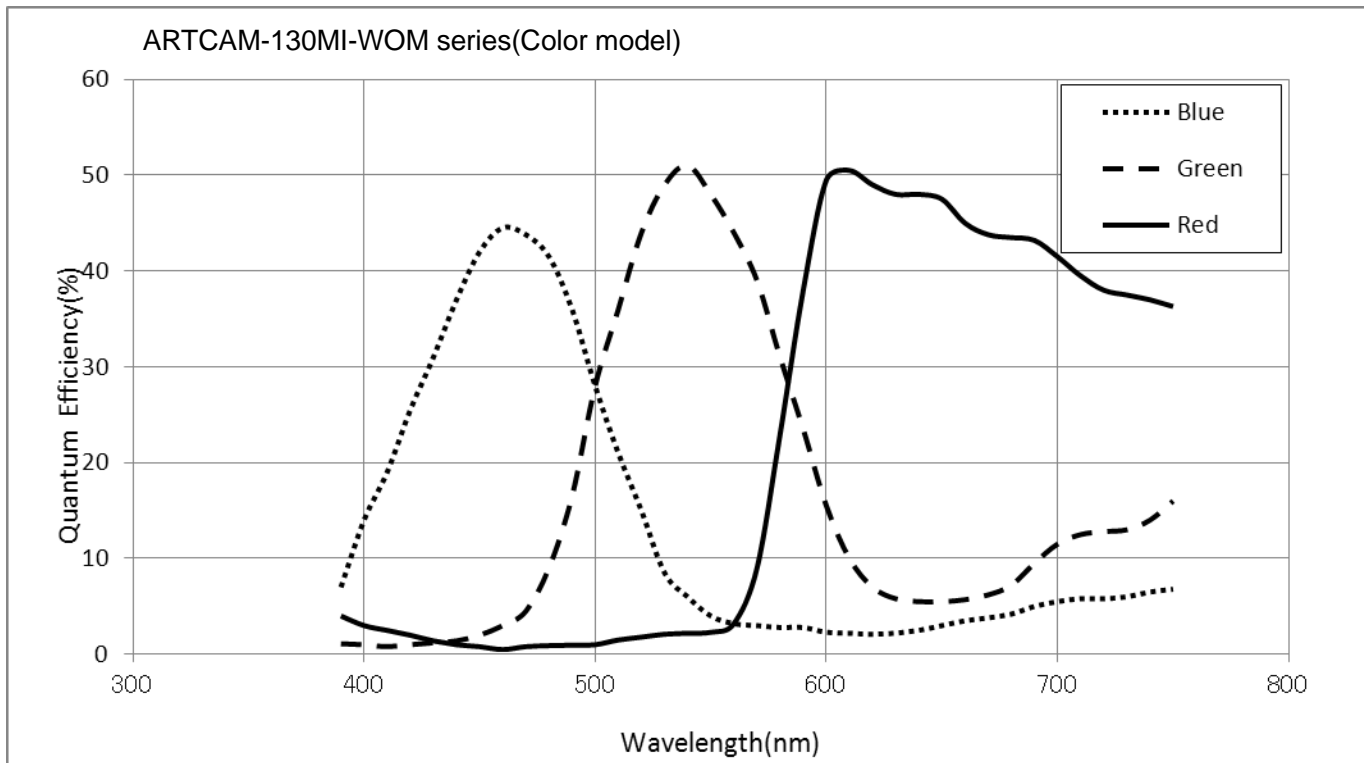

### 8.4. ARTCAM-130MI-BW-WOM series(Monochrome model)

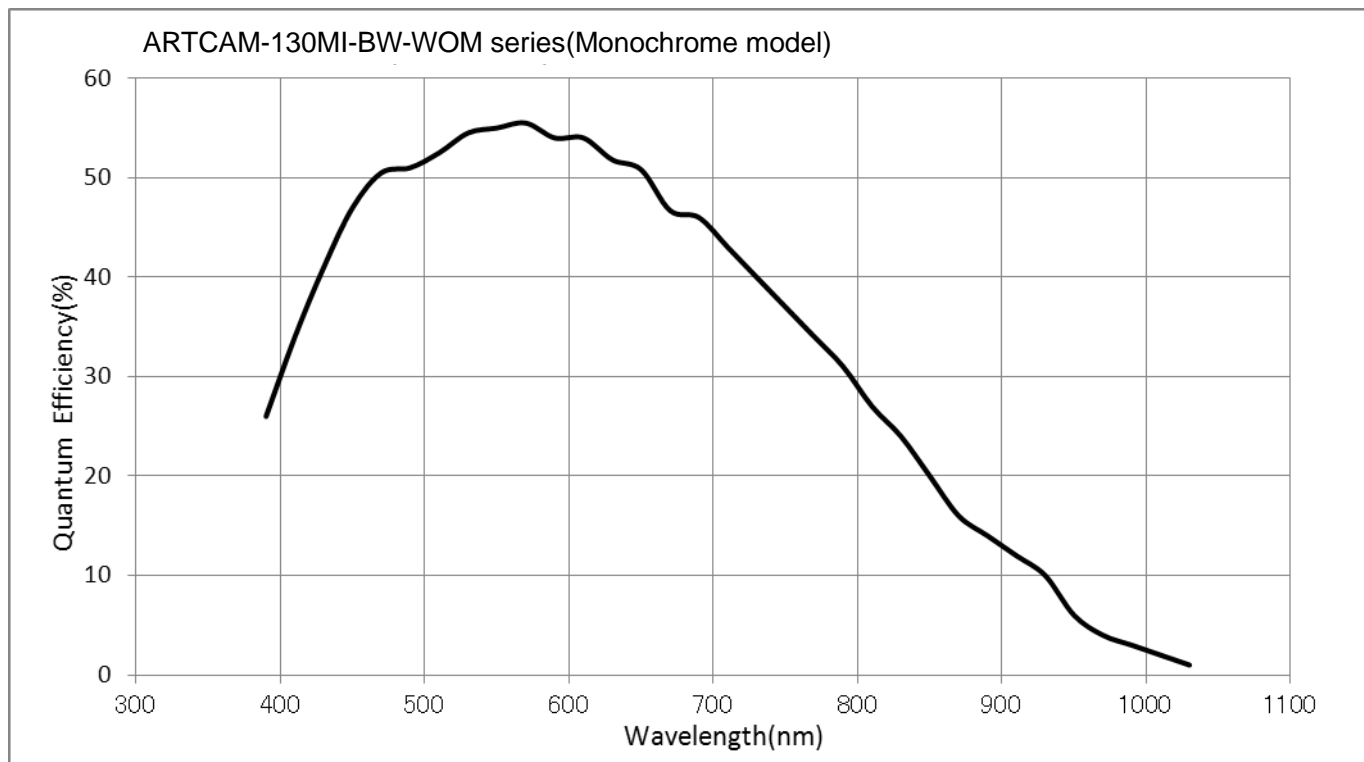

### 8.5. ARTCAM-300MI-WOM series(Color model)

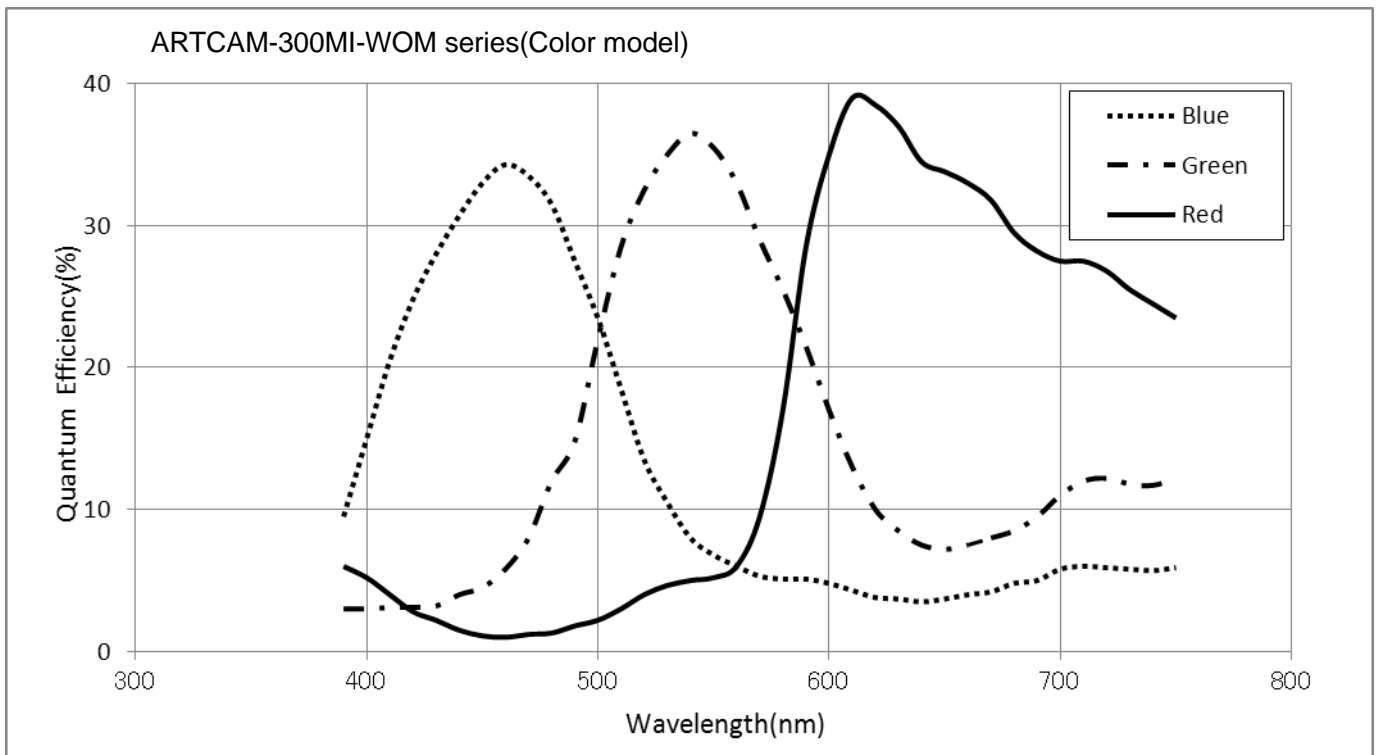

### 8.6. ARTCAM-500MI-WOM series(Color model)

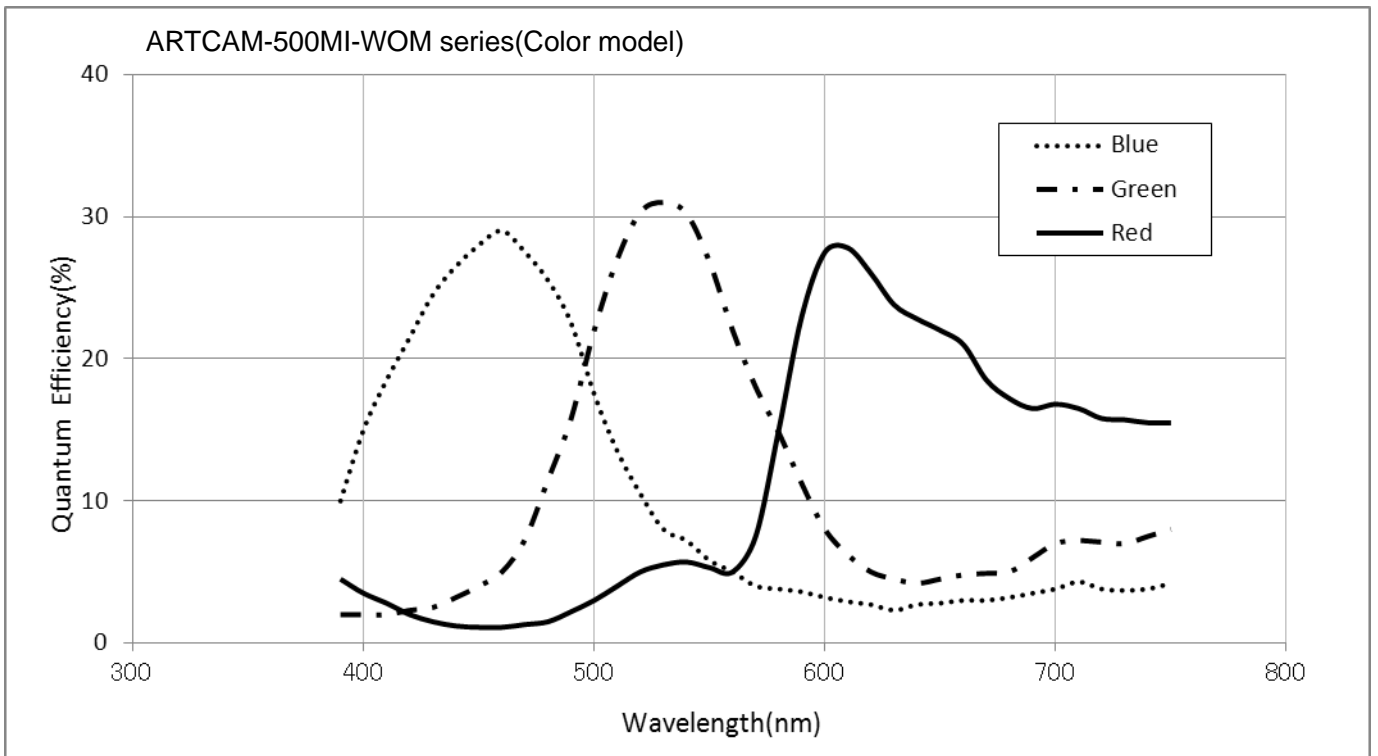

### 8.7. ARTCAM-500MI-BW-WOM series(Monochrome model)

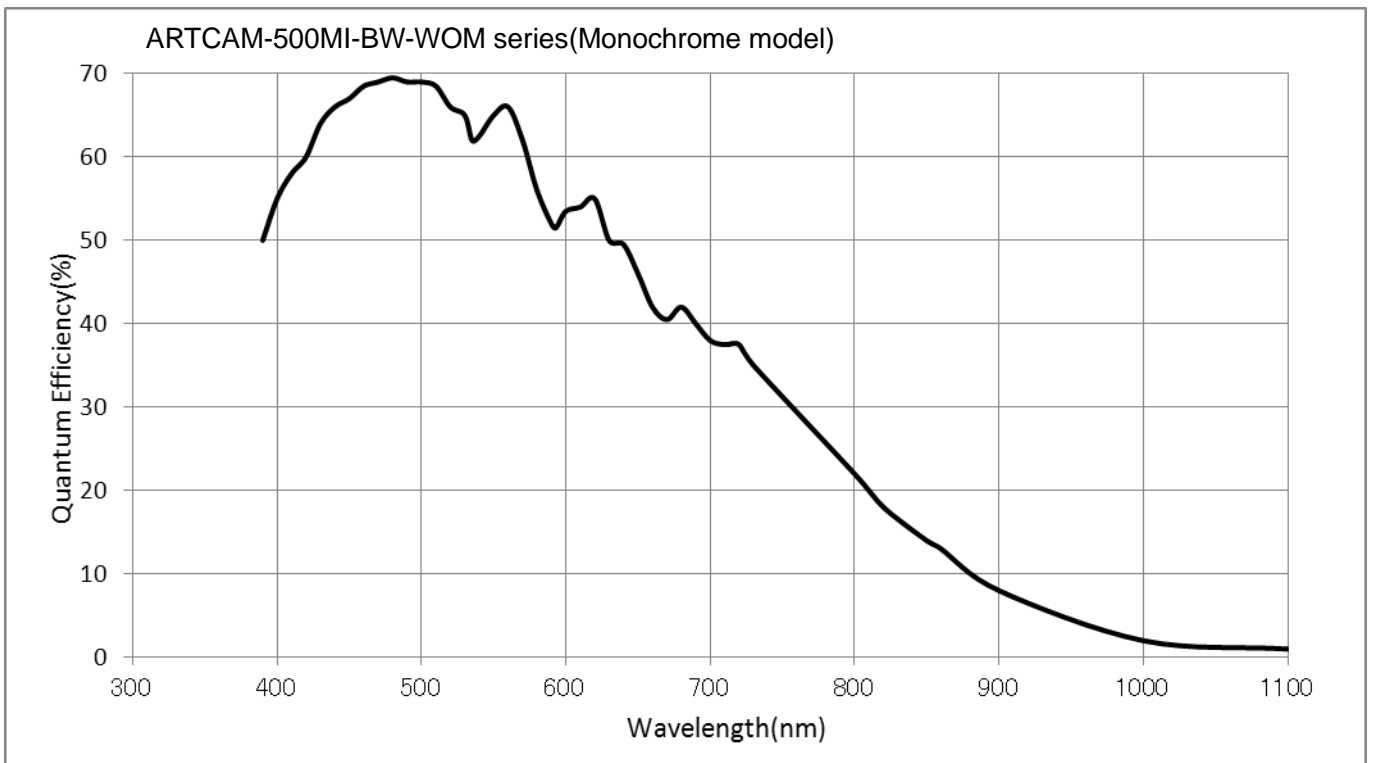

### 8.8. ARTCAM-1000MI-WOM series(Color model)

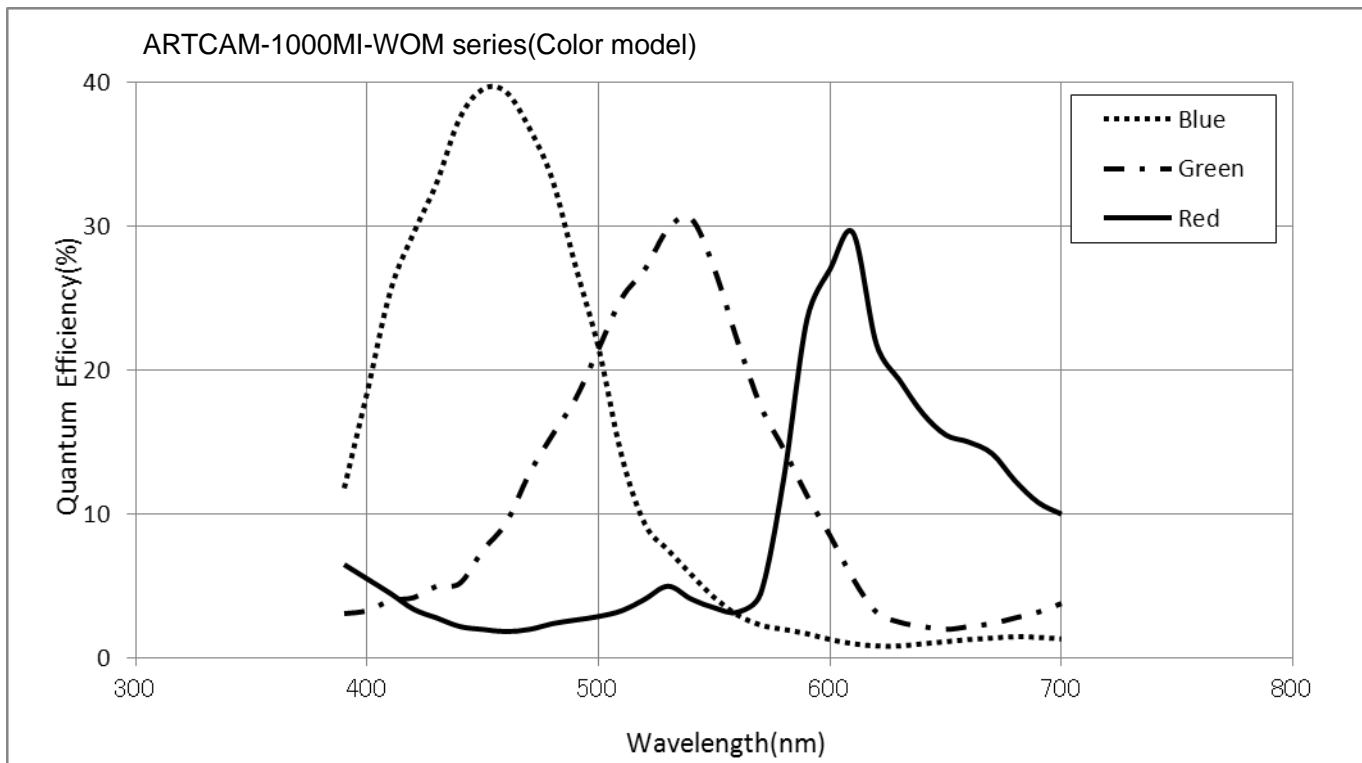

### 8.9. ARTCAM-1000MI-BW-WOM series(Monochrome model)

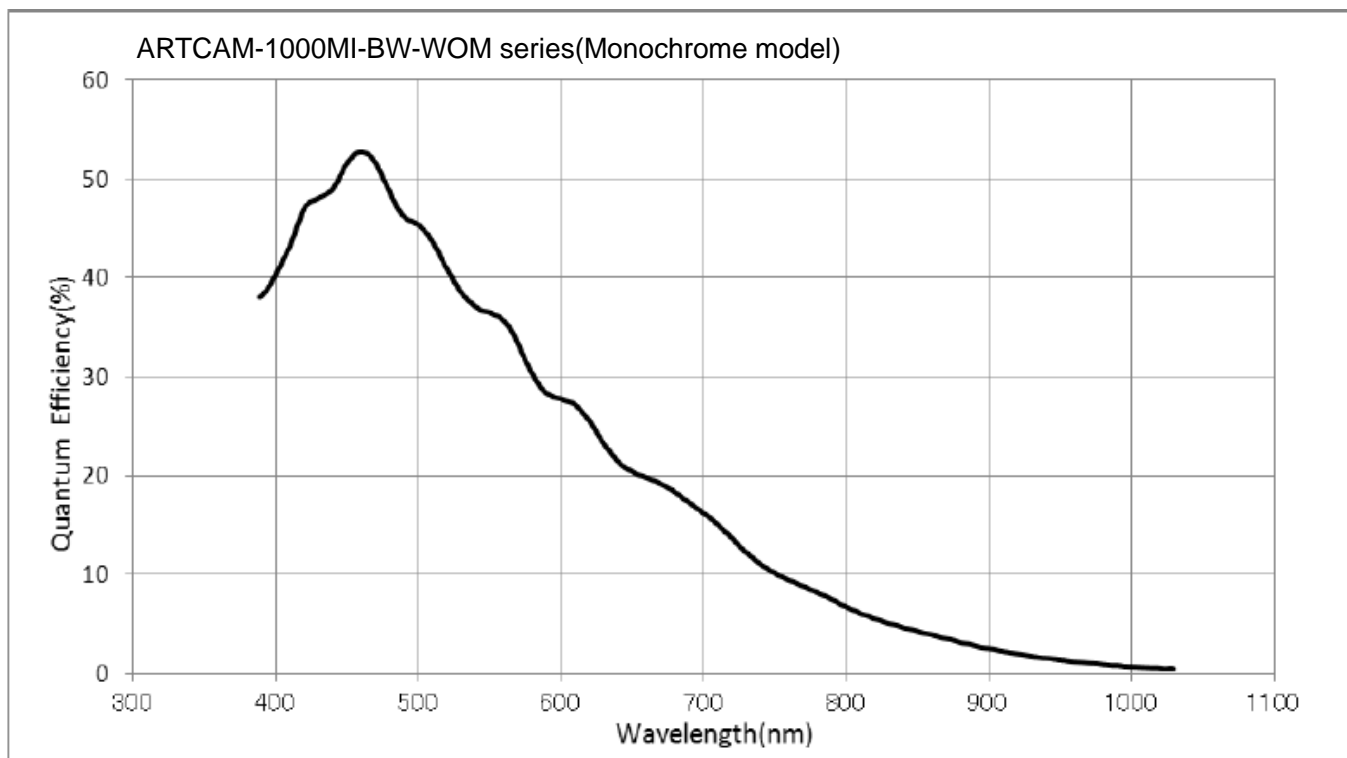

### 8.10. ARTCAM-1400MI-WOM series(Color model)

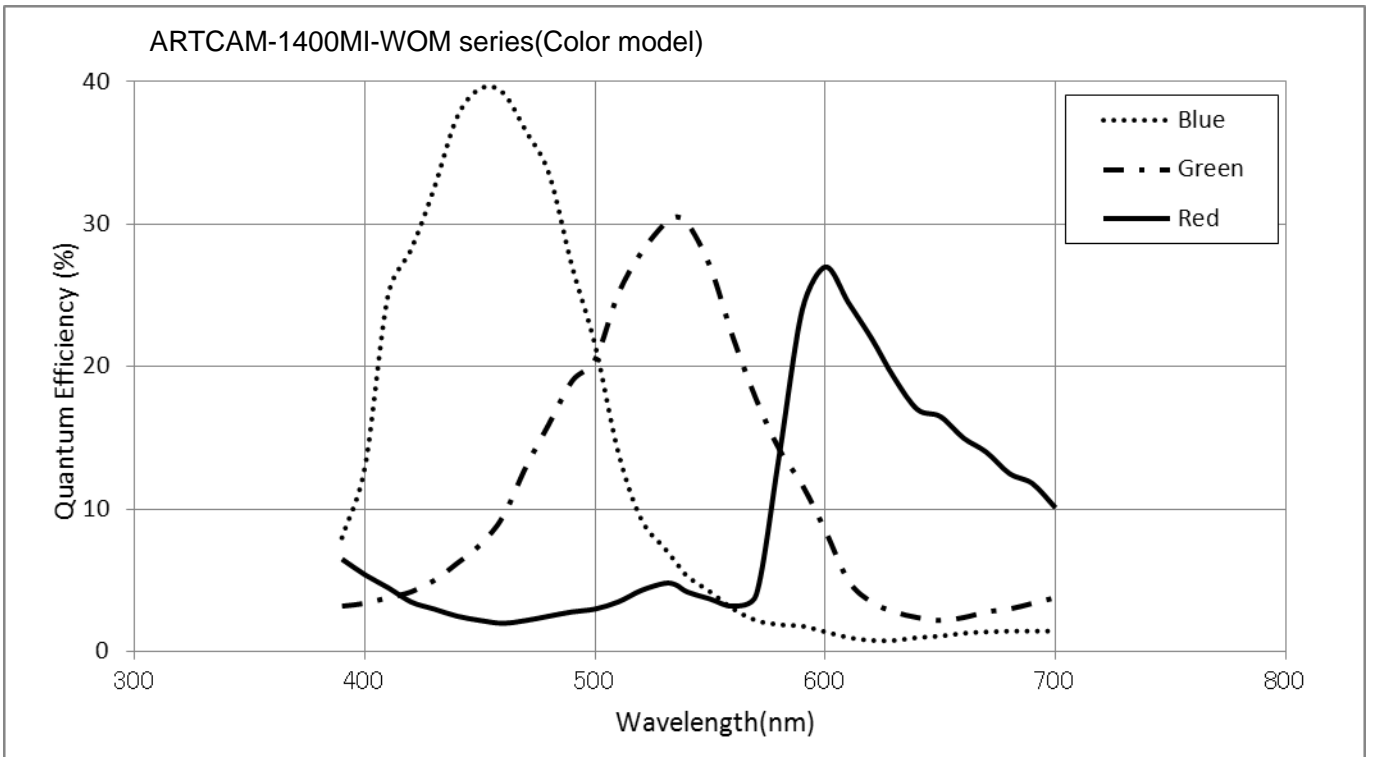

## 9. Characteristic of visible light cut filter

Near-infrared model (NIR) is adopting R70 on visible cut filter.

Please check the spectral sensitivity characteristic of image sensor as well.

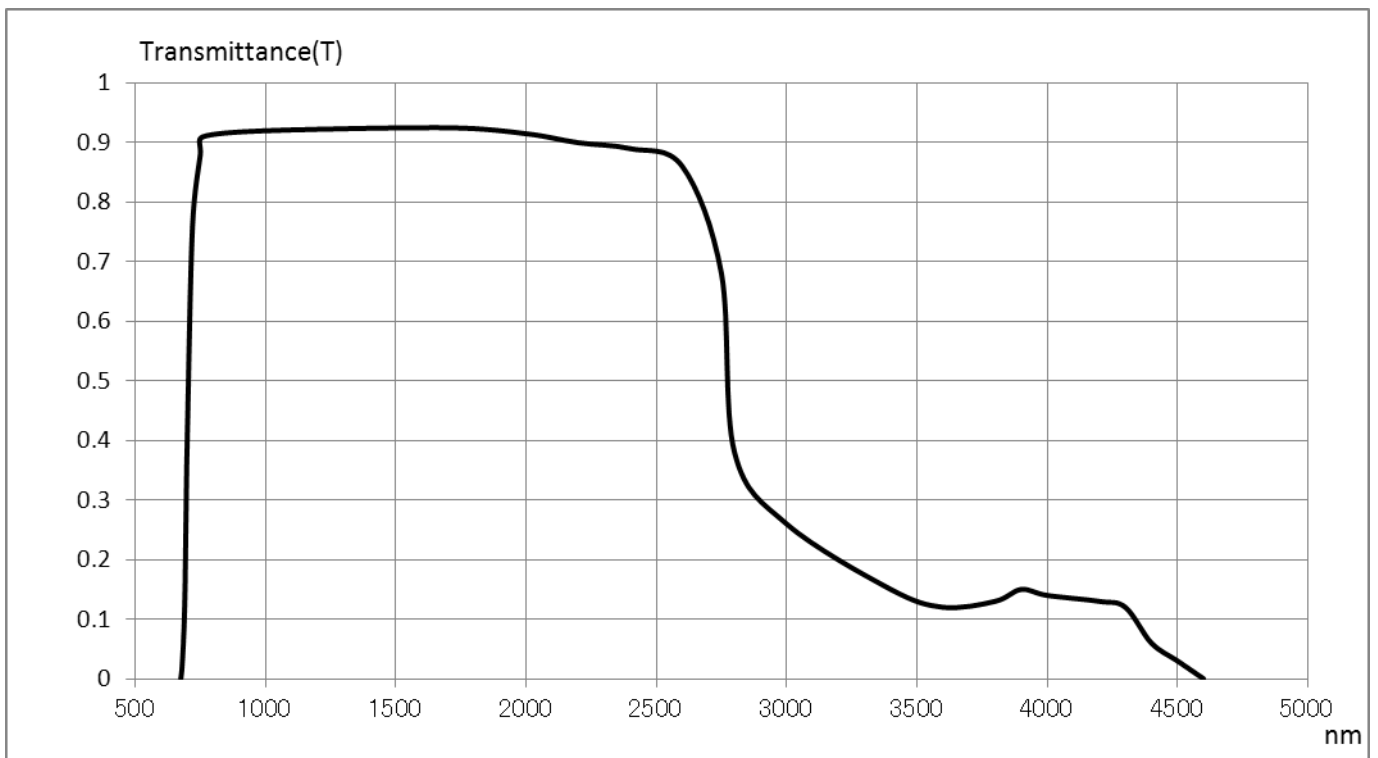



## 10. AD Conversion

### 10.1. ARTCAM-036MI2-WOM series / 130MI-WOM series / 300MI-WOM series / 500MI-WOM series

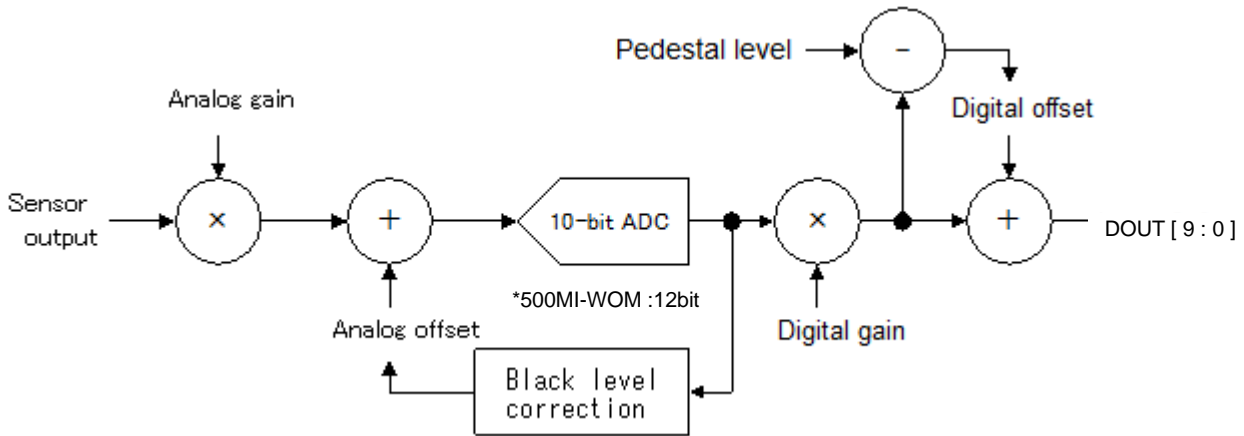

#### 10.1.1. Standard functions (configurable in standard viewer/SDK)

- Analog gain

Global gain (analog gain) can be configured with the standard viewer software or SDK.

Setting range on standard viewer software: 0 – 63 (x0 to x7.875)

Default value on standard viewer software: 14

Analog gain = gain value \* 0.125

Example 1) when the setting value is 16:

$$\text{Analog gain} = 16 * 0.125 = x2.0$$

#### 10.1.2. Optional functions (please contact us for further details.)

- Analog gain: (130MI-WOM / 300MI-WOM / 500MI-WOM series)

The range of analog gain could be doubled (maximum x15.75).

- Digital gain (300MI-WOM / 500MI-WOM series)

The digital gain on this camera is fixed at x1 and its maximum value can be set up to x16.

- Black level correction

By default, black level correction is set automatically, and the Pedestal level is set to 42 at 10bit. (When output is at 8bit, the Pedestal level is approximately  $42 / 4 = 10.5$ .)

Black level correction could also be set manually by the SDK.

The target value of Pedestal level (42) can also be modified.

(The Pedestal level on 500MI-WOM series is set to 168 at 12bit. When output is 8bit, the Pedestal level is approximately  $168 / 16 = 10.5$ .)

## 10.2. ARTCAM-1000MI-WOM series

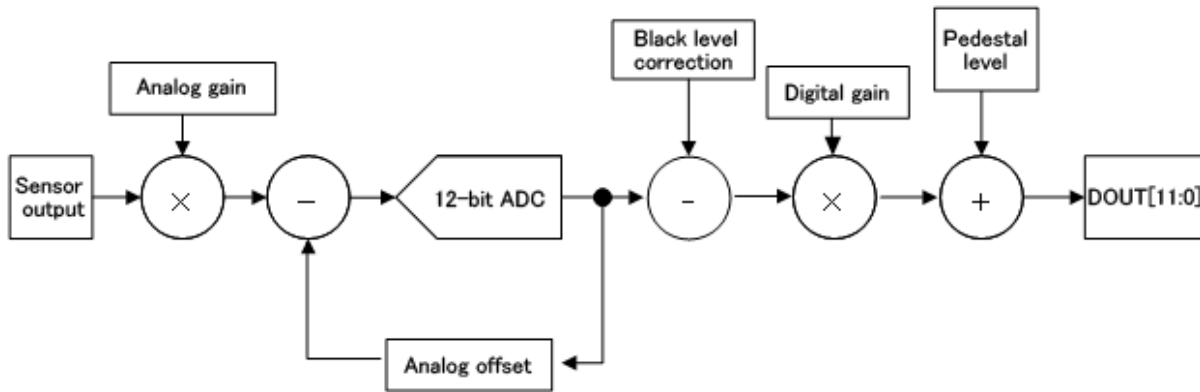

### 10.2.1. Standard functions (configurable in standard viewer/SDK)

- Analog gain

Global gain (analog gain) can be configured with the standard viewer software or SDK.

Setting range on standard viewer software: 0 – 127 (x0 to x1.984375)

Default value on standard viewer software: 64

Analog gain = gain value \* 0.015625

Example 1) when the setting value is 64:

$$\text{Analog gain} = 64 * 0.015625 = x1.0$$

### 10.2.2. Optional functions (please contact us for further details.)

- Analog gain:

The analog range can be set up to 24 times by the standard viewer and SDK.

- Digital gain:

The digital gain on this camera is fixed at x1 and its maximum value can be set up to x7.

- Black level correction:

By default, black level correction is set automatically,

and the Pedestal level is set to 168 at 12bit.

(When output is at 8bit, the Pedestal level is approximately  $168 / 16 = 10.5$ )

Black level correction could also be set manually by the SDK.

The target value of Pedestal level (168) can also be modified.

### 10.3. ARTCAM-1400MI-WOM series

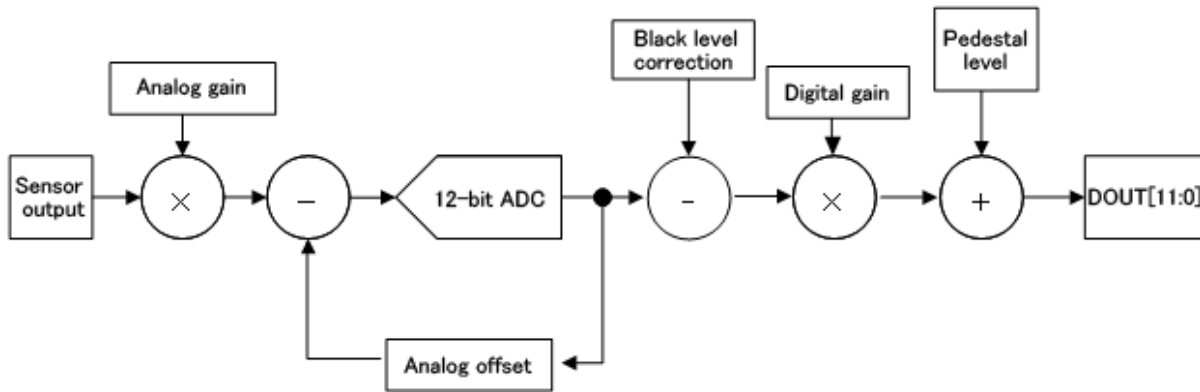

#### 10.3.1. Standard functions (configurable in standard viewer/SDK)

- Analog gain

Global gain (analog gain) can be configured with the standard viewer software or SDK.

Setting range on standard viewer software: 0 – 127 (x0 to x1.984375)

Default value on standard viewer software: 64

Analog gain = gain value \* 0.015625

Example 1) when the setting value is 64:

$$\text{Analog gain} = 64 * 0.015625 = x1.0$$

Setting range on standard viewer software: 0 – 127 (x0 to x3.96875)

Default value on standard viewer software: 32

Analog gain = gain value \* 0.03125

Example 1) when the setting value is 32:

$$\text{Analog gain} = 32 * 0.03125 = x1.0$$

#### 10.3.2. Optional functions (please contact us for further details.)

- Analog gain:

The range of analog gain could be quadrupled.

- Digital gain:

The digital gain on this camera is fixed at x1 and its maximum value can be set up to x7.

- Black level correction:

By default, black level correction is set automatically, and the Pedestal level is set to 168 at 12bit.

(When output is at 8bit, the Pedestal level is approximately  $168 / 16 = 10.5$ )

Black level correction could also be set manually by the SDK.

The target value of Pedestal level (168) can also be modified.

# 11. Optional Functions

## 11.1. Trigger Input

ARTCAM-MI-WOM series are designed with external trigger.

\*External trigger function is not available on ARTCAM-1000MI-WOM and ARTCAM-1400MI-WOM series.

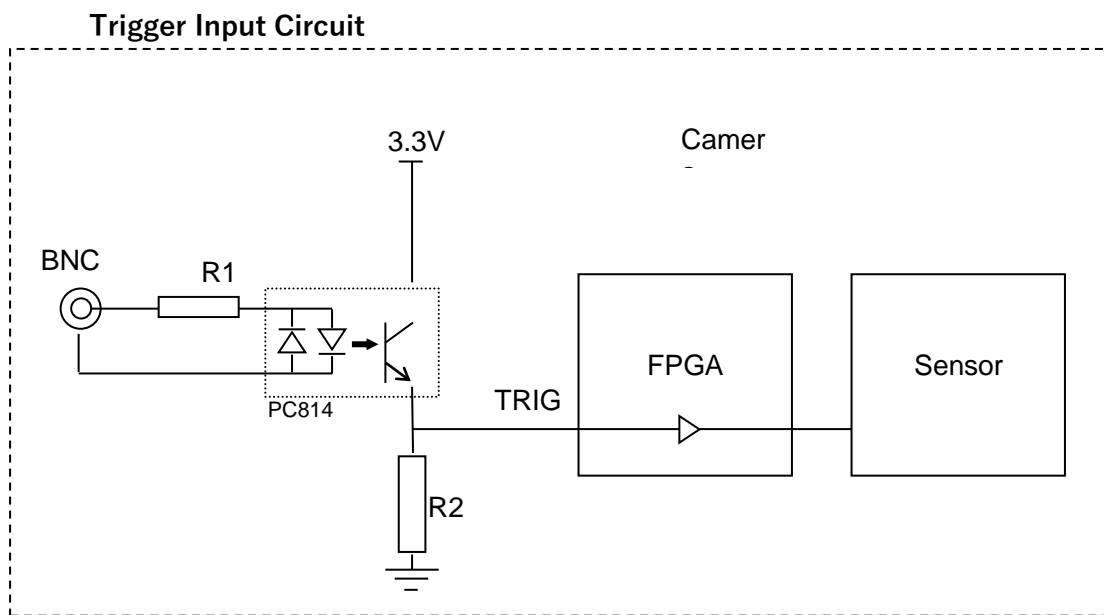

R1 = 2.4k $\Omega$

R2 = 10k $\Omega$

11.1.1. Trigger timing chart(ARTCAM-036MI2-WOM series)

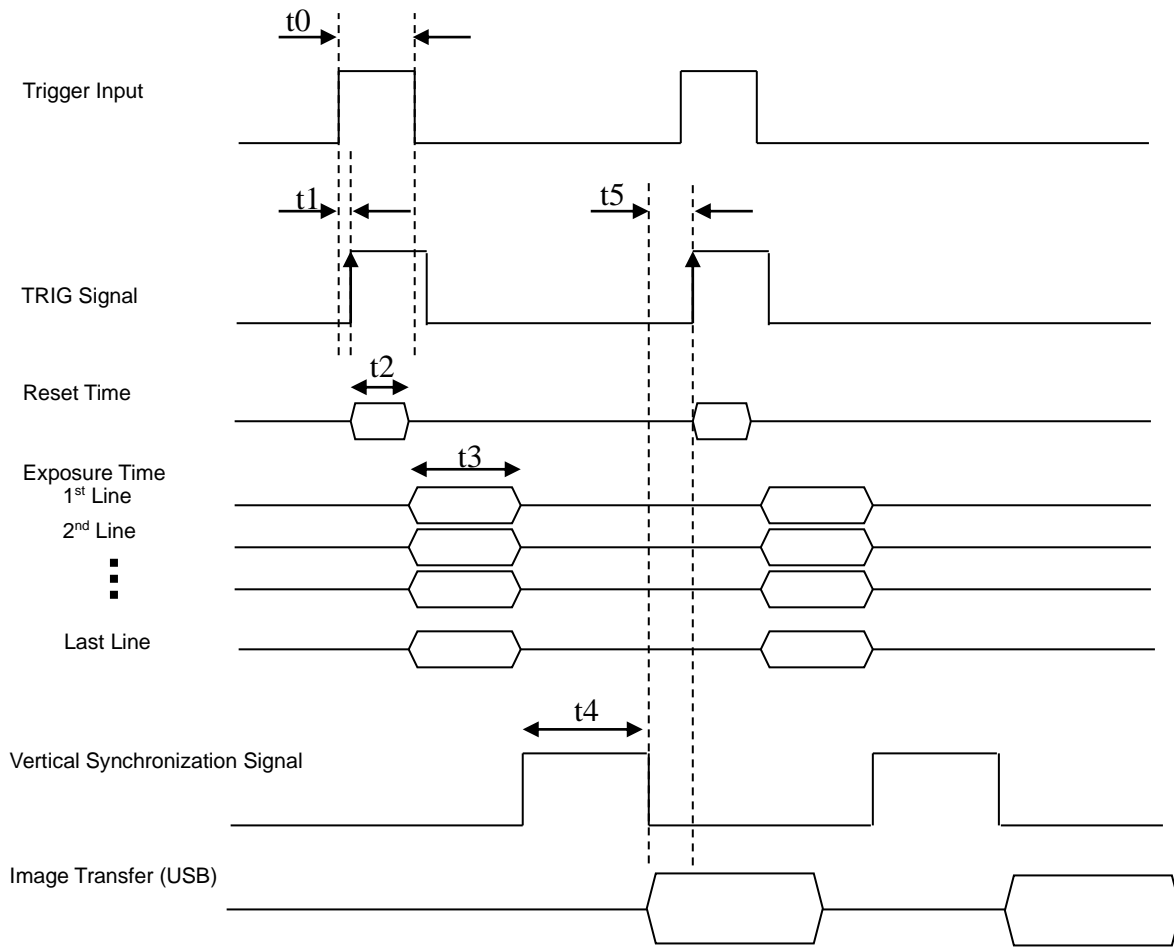

t0	Input Pulse Width	Above 1ms
t1	Photo Coupler Delay	1~99 $\mu$ s (Subject to Input Pulse Voltage)
t2	Reset Time	6 * 1H
t3	Exposure Time	Subject to Shutter Speed Settings
t4	Frame Transfer	Subject to ROI Settings and Operation Clock
t5	Effective Trigger for next frame	Approximate 100H after the Vertical Synchronization Signal transits to a low voltage

\*1H = (640+64)  $\times$  0.0417 [ $\mu$ s]

11.1.2. Trigger timing chart(ARTCAM-130MI-WOM/300MI-WOM series)

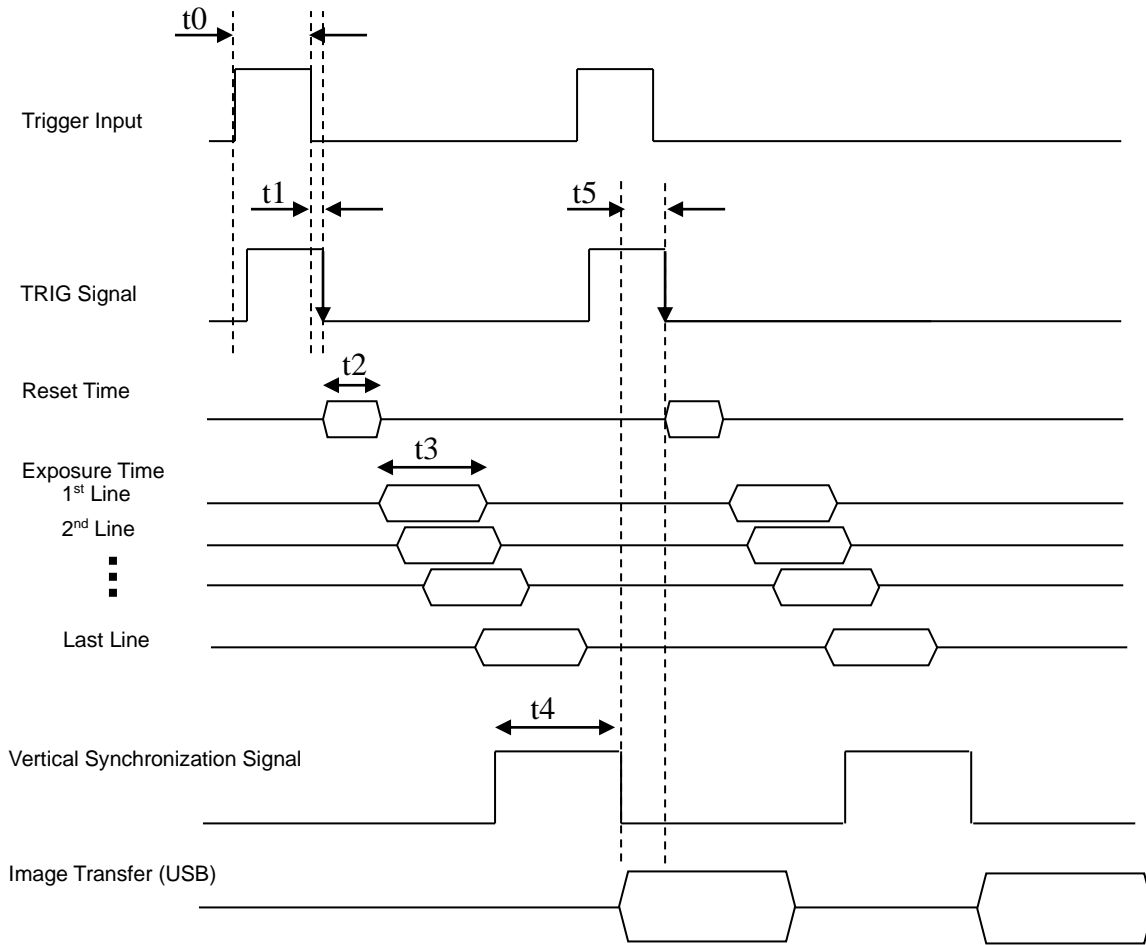

t0	Input Pulse Width	Above 1ms
t1	Photo Coupler Delay	1~99 $\mu$ s (Subject to Input Pulse Voltage)
t2	Reset Time	9 * 1H(ARTCAM-130MI series) 18 * 1H(ARTCAM-300MI series)
t3	Exposure Time	Subject to Shutter Speed Settings
t4	Frame Transfer	Subject to ROI Settings and Operation Clock
t5	Effective Trigger for next frame	Approximate 100H after the Vertical Synchronization Signal transits to a low voltage

\*130MI-WOM 1H =  $(1280+244) \times 0.020833 [\mu s]$

300MI-WOM 1H =  $(2048+390) \times 0.020833 [\mu s]$

11.1.3. Trigger timing chart(ARTCAM-500MI-WOM series)

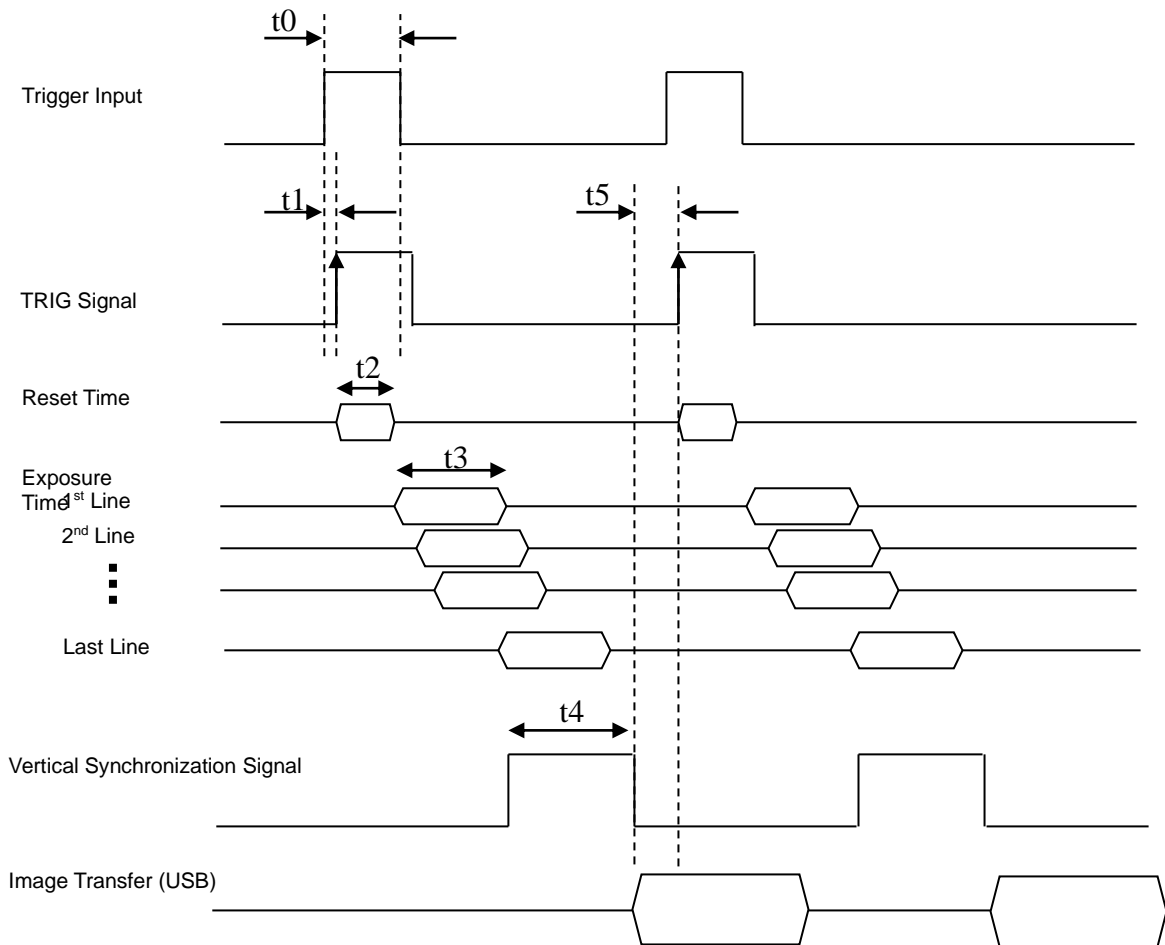

t0	Input Pulse Width	Above 1ms
t1	Photo Coupler Delay	1~99 $\mu$ s (Subject to Input Pulse Voltage)
t2	Reset Time	8 * 1H
t3	Exposure Time	Subject to Shutter Speed Settings
t4	Frame Transfer	Subject to ROI Settings and Operation Clock
t5	Effective Trigger for next frame	Approximate 100H after the Vertical Synchronization Signal transits to a low voltage

\*1 For ARTCAM-500MI, the image will be acquired when the trigger signal transits from a low voltage to a high one. If the trigger signal stays at a high level, the trigger time cycle will repeat automatically and image will be acquired continuously.

\*2 1H = (2592+912)  $\times$  0.020833 [ $\mu$ s]

## 11.2. GPIO

GPIO option is available upon request before the delivery of the ARTCAM-MI-WOM series.

Pin assign

No.	Function
1	GPIO_0
2	GPIO_1
3	GPIO_2
4	VCC(3.3V) Maximum output 50mA
5	GPIO_3
6	GPIO_4
7	GPIO_5
8	Gnd

• Each of the six GPIO pins is pulled up to 3.3V with 1k $\Omega$  on the circuit board and is connected to the IO pins on FPGA.

• When GPIO pins are used as output pins, the FPGA output is driven at high impedance and Low level.

(At the time of power-up: high impedance)

To control GPIO, please use the ArtCam\_SetIOPort / GetIOPort functions in SDK.

To control GPIO output, please specify the corresponding OR calculated values of each bit as per the table below to the second argument of the SetIOPort function.

IO pin	Bit
GPIO_0	0x01
GPIO_1	0x02
GPIO_2	0x04
GPIO_3	0x08
GPIO_4	0x10
GPIO_5	0x20

For example, to have GPIO\_0, GPIO\_1, GPIO\_4 output High(Z) and GPIO\_2, GPIO\_3, GPIO\_5 output Low, please call this as follows:

```
ArtCam_SetIOPort(hACam, (0x01 | 0x02 | 0x10), 0, 0);
```

To read the GPIO pins, BYTE-type values can be gotten with the GetIOPort function.

For example, to get the status on GPIO\_4 pin, please call the followings:

```
BYTE data = 0x00;
```

```
ArtCam_GetIOPort(hACam, &data, 0, 0);
```

```
BOOL gpio4 = (data & 0x10) ? TRUE : FALSE;
```

And the BOOL-type variable gpio4 of GPIO\_4 pin is gotten

• Extensions

Monitoring the vertical synchronization signals, horizontal synchronization signals, strobe signals, and trigger signals on the sensor are possible as extensions of the GPIO option. (Optional)



## 12. System Requirements

### 12.1. Recommended System Requirements

- Host Controller

This camera is applicable to USB 2.0.

- CPU

The driver of this camera is applicable to computer architecture “x86” or “amd64”.

The specification of CPU effects directly the imaging process speed, therefore it is highly recommended to utilize a high-end CPU if possible.

- Memory

In the viewer software, there is a data buffer which can store 4 to 8 frames.

Therefore, it is necessary to keep spare space at least for 8 frames in the memory.

(For example, when using 1.3MP color camera,  $1280 \times 1024 \times 3 \times 8$  [byte] = 30[MB] is necessary.)

It is highly recommended to keep enough memory space especially when using high resolution camera.

- OS

This camera is applicable only to the architecture of Windows NT (32bit/64bit).

Standard functions are confirmed with OS after Windows 7.

In addition, it is recommended to use Windows 10.



## Caution

■ Please refer the restrictions below when you use ARTCAM series.

### (1) Recommended System Requirements

If the system specifications do not meet the requirements recommended above, it may be difficult to run at the maximum frame rate.

### (2) Connection of Multiple USB Devices

When connecting multiple USB devices to one USB host controller, some USB device may fail to function stably depending on the specifications of the host controller.

(Problem of power supply, data transfer bandwidth, etc.)

To avoid power supply problem, it is recommended to use powered USB hub.

### (3) USB2.0 Cable Extension

We cannot guarantee the functionality of the USB2.0 camera if the user adopts USB2.0 extension cables or repeaters which are not confirmed by us. With the extension cables or repeaters, the bandwidth of transfer may differ, and thus caused malfunctions such as a low frame rate or recognition failure on the camera.

What may cause the problem is that the regulation of the power lines becomes not enough, and so causes impedance mismatch on data signals.

\*For the recommended extension cable, please contact our sales department.

(TEL: +81-3389-5488)

ARTRAY CO., LTD. Obtained ISO 9001: 2015 2018/9/17

1-17-5 Kouenjikota, Suginami-ku, Tokyo 166-0002 Japan

Tel: +81-3-3389-5488

Fax: +81-3-3389-5486

Email: sales@artray.us

URL: www.artray.us

**ARTRAY**